



ODS – ORIGA DRIVE SYSTEM

Driving the future.

ORIGA – simply the first

aerospace
climate control
electromechanical
filtration
fluid & gas handling
hydraulics
pneumatics
process control
sealing & shielding



ENGINEERING YOUR SUCCESS.

EL Sizing

The dimensioning program for electric linear drives

Available on CD-Rom or as a download

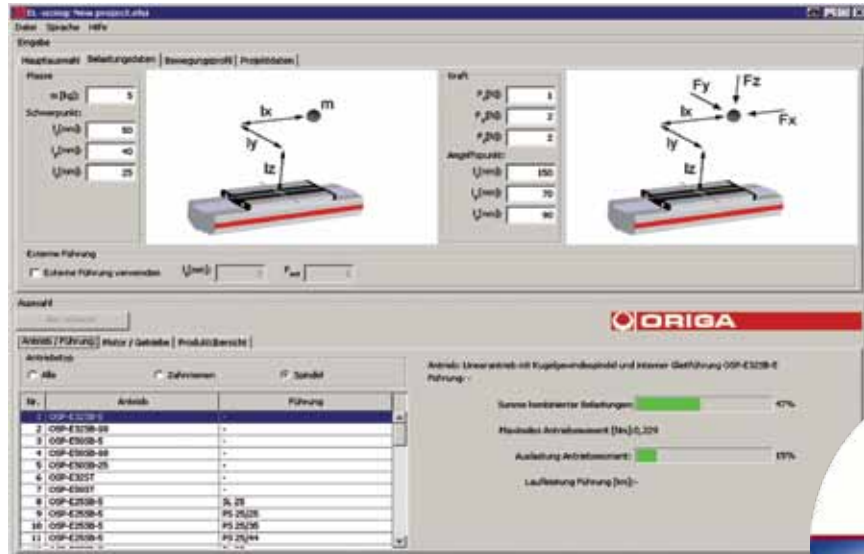

Coming soon for ODS – ORIGA DRIVE SYSTEM

ORIGA DRIVE SYSTEM

ODS series

Table of contents

	Page
Product overview	4
Profile versions	6
Ball bearing guide	7
Ball screw	9
- Drive data	10
- Performance	11
- Dimensions	12
- Weight, mass and inertia	13
- Order stroke	14
- Product key	15
Belt	17
- Drive data	18
- Thrust forces	19
- Dimensions	20
- Weight, mass, inertia	21
- Order stroke	22
- Product key	23
Options	25
- Protection class	26
- Impact protection	27
- Position detection	28
- Displacement measuring system	30
Accessories	33
- Coupling housing	34
- Motor coupling	35
- T-Slot mountings	36
Drive combinations	38

ODS – ORIGA DRIVE

Driving the future



Profile designs



Mounting systems



Guide systems



Lubrication



Protection classes

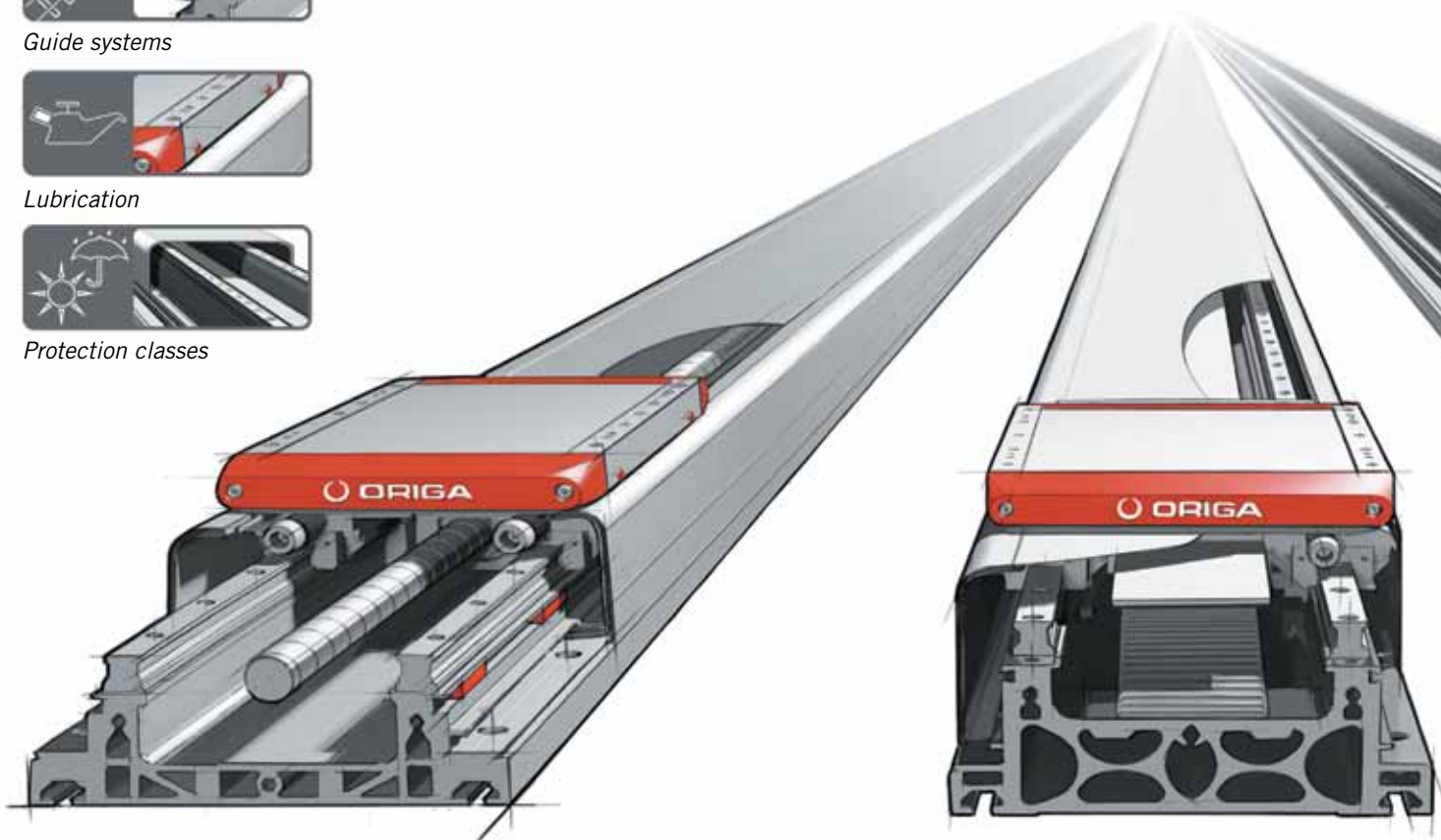

Screw drive

The solution for precise path and position control for medium loads



Toothed belt drive

The solution for fast path and position control for medium loads

VE SYSTEM

re.

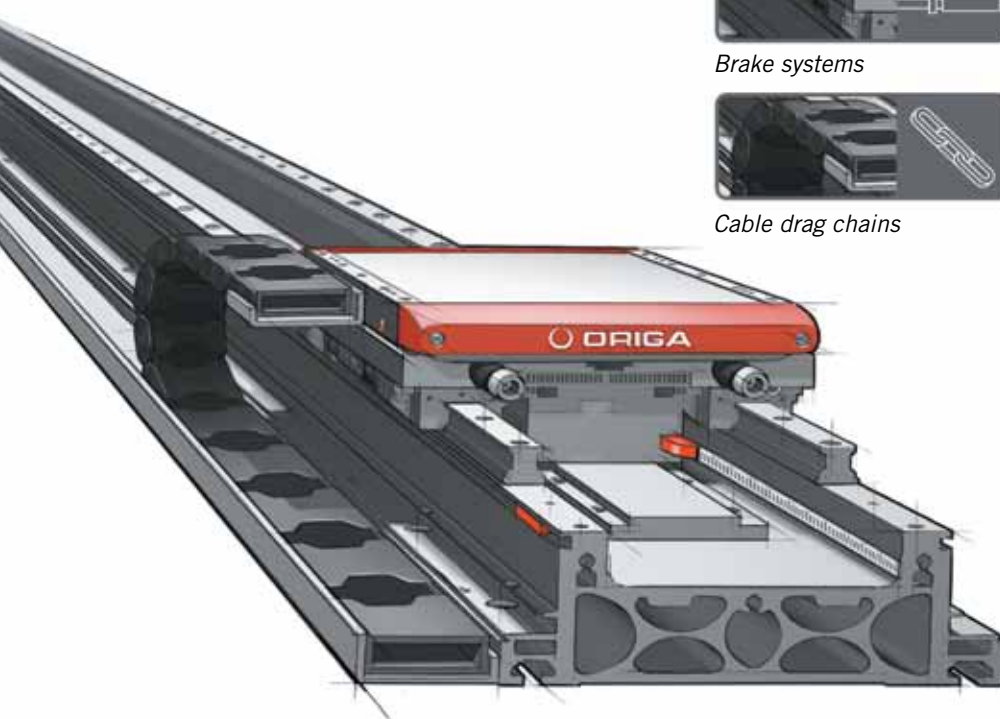

Position sensing



Impact protection

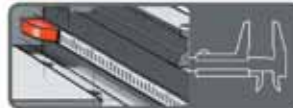

Distance measurement



Brake systems



Cable drag chains

ORIGA DRIVE SYSTEM

Profile designs

- Basic profile for assembling directly to the machine base
- Reinforced profile for self-supporting assembly

Mounting systems

- Integrated T-slots for attaching from below
- Standard or customized hole pattern for attaching from above

Guide systems

- Plain bearing guide
- Recirculating ball bearing guide

Lubrication

- Central lubrication via externally accessible lubricating nipples

Protection classes

- Without cover: IP20
- With cover: IP54

Position sensing

- Integrated, adjustable position switch for end positions and homing

Impact protection

- Integrated shock absorbers for both end positions

Distance measurement

- Contact-free, incremental displacement measuring system

Brake system

- Holding brake can be implemented for horizontal and vertical movements

Cable drag chains

- Directly attachable drag chains for various cabling



Linear drive

The solution for fast travel with the greatest possible dynamics and precision

ORIGA DRIVE SYSTEM

ODS series

Profile versions

Sizes:
145, 175, 225 mm

Designs

- Basic
- Reinforced

The ODS linear drive system can be equipped with a “basic” or “reinforced” profile as standard. The “basic” profile is suitable for fitting directly to a machine base that has a corresponding support surface.

The “reinforced” profile, on the other hand, is the preferred choice for self-supporting multi-axis systems or for use in conjunction with a base surface offering limited support.

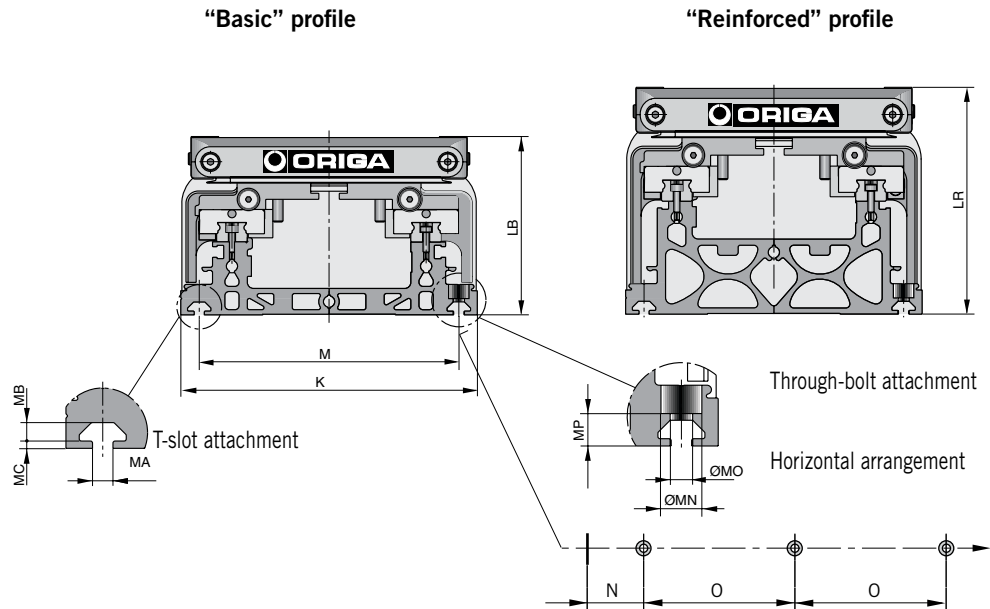

Dimension Table – Profile versions

Type	K	LB	LR	M	MA	MB	MC	ØMN	ØMO	MP	N	O
ODS-145	145.0	88.0	112.0	127.0	5.0	4.55	1.8	10.0	5.5	8.0		80.0
ODS-175	175.0	111.5	134.5	150.0	6.2	6.75	3.0	11.0	6.6	14.0	on request	120.0
ODS-225	225.0	125.0	153.0	195.0	8.0	8.00	4.5	15.0	9.0	15.5		120.0

Dimensions in mm

Loads, forces and bending moments

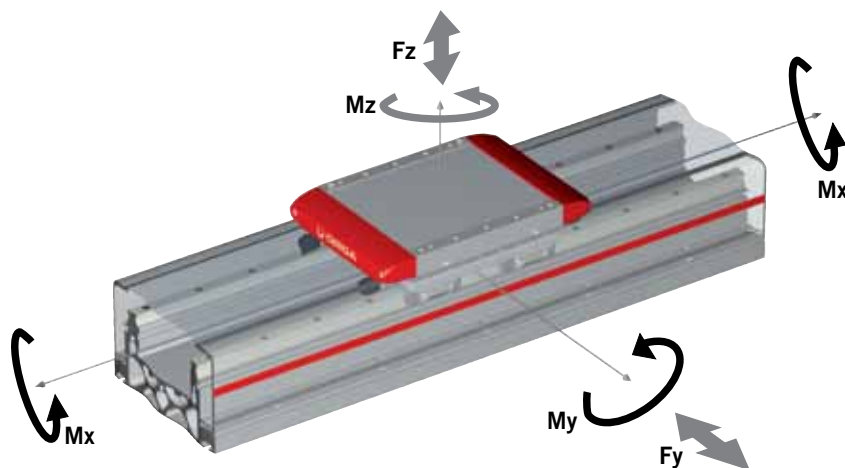

ORIGA DRIVE SYSTEM

ODS series

Ball bearing guide

Sizes:
145, 175, 225 mm

Load requirements for guides and installation size.

The occurring loads, forces and bending moments depend on the application. The mass of the construction attached to the carriage has a center of gravity. This mass creates static forces ($F = m \cdot g$) and bending moments ($M = m \cdot a \cdot l$) arise in dependence of the acceleration during travel. Care should be taken when selecting suitable guides that the permissible sum of loads does not exceed 1.

Combined loads

The maximum permissible load for linear drives subject to simultaneous multiple loads, forces and bending moments are calculated

using the formula below. Maximum permissible loads must not be exceeded.

$$L = \frac{F_y}{F_{y(max)}} + \frac{F_z}{F_{z(max)}} + \frac{M_x}{M_{x(max)}} + \frac{M_y}{M_{y(max)}} + \frac{M_z}{M_{z(max)}} \leq 1$$

The sum of all loads must under no circumstance be > 1.

Internal lever arm l_{zi}

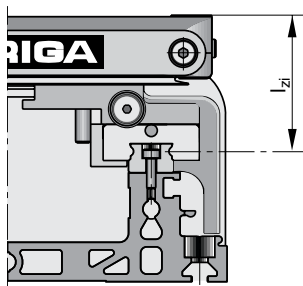

Dimension table l_{zi}

Type	l_{zi}
ODS-145	[mm] 45
ODS-175	[mm] 56
ODS-225	[mm] 63

Maximum permissible load based on a service life of 8000 km

Design	Standard (1 carriage as standard)			Tandem (2 carriage as standard)		
	ODS-145	ODS-175	ODS-225	ODS-145	ODS-175	ODS-225
Max. permissible force						
F_{z8000} F_{y8000}	[N] 3,000	5,000	10,000	4,500	7,500	15,000
Max. bending moment						
M_{x8000}	[Nm] 150	300	950	225	450	1,425
M_{y8000}	[Nm] 150	300	950	225	450	1,425
M_{z8000}	[Nm] 150	300	950	225	450	1,425

ODS Ball screw



ORIGA DRIVE SYSTEM

ODS-...SB series

Ball screw

Drive data

*Sizes:
145, 175, 225 mm*

Load values – size ODS-145SB

Type of screw			16 x 5	16 x 10	16 x 16
Pitch	p	[mm]	5	10	16
Max. speed	$v_{max.}$	[m/s]	0.25	0.50	0.80
Max. acceleration	$a_{max.}$	[m/s ²]	10	10	10
Max. thrust force	F_{A1000}	[N]	2,200	1,600	1,800
	F_{A8000}	[Nm]	1,100	840	900
Max. torque	$M_{max.1000}$	[N]	2.5	3.5	5.7
	$M_{max.8000}$	[Nm]	1.6	2.2	3.2
No load torque	M_0	[Nm]	0.6	0.7	0.7
Repeatability		[mm]	± 0.01	± 0.01	± 0.01
Max. order stroke		[mm]	2,000	2,000	2,000

Load values – size ODS-175SB series

Type of screw			20 x 5	20 x 10	20 x 20
Pitch		[mm]	5	10	20
Max. speed	$v_{max.}$	[m/s]	0.25	0.50	1.00
Max. acceleration	$a_{max.}$	[m/s ²]	10	10	10
Max. thrust force	F_{A1000}	[N]	2,900	3,400	3,300
	F_{A8000}	[N]	1,300	1,700	1,650
Max. torque	$M_{max.1000}$	[Nm]	3.2	6.7	12.3
	$M_{max.8000}$	[Nm]	1.8	3.7	6.6
No load torque	M_0	[Nm]	0.7	0.8	0.9
Repeatability		[mm]	± 0.01	± 0.01	± 0.01
Max. order stroke		[mm]	2,500	2,500	2,500

Load values – size ODS-225SB series

Type of screw			25 x 5	25 x 10	25 x 25
Pitch		[mm]	5	10	25
Max. speed	$v_{max.}$	[m/s]	0.25	0.50	1.25
Max. acceleration	$a_{max.}$	[m/s ²]	10	10	10
Max. thrust force	F_{A1000}	[N]	3,500	4,700	5,000
	F_{A8000}	[N]	1,300	2,400	2,600
Max. torque	$M_{max.1000}$	[Nm]	3.8	9.0	22.6
	$M_{max.8000}$	[Nm]	1.9	5.1	12.2
No load torque	M_0	[Nm]	0.8	0.9	1.0
Repeatability		[mm]	± 0.01	± 0.01	± 0.01
Max. order stroke		[mm]	3,200	3,200	3,200

Performance subjected to thrust force requirements – size ODS-145SB

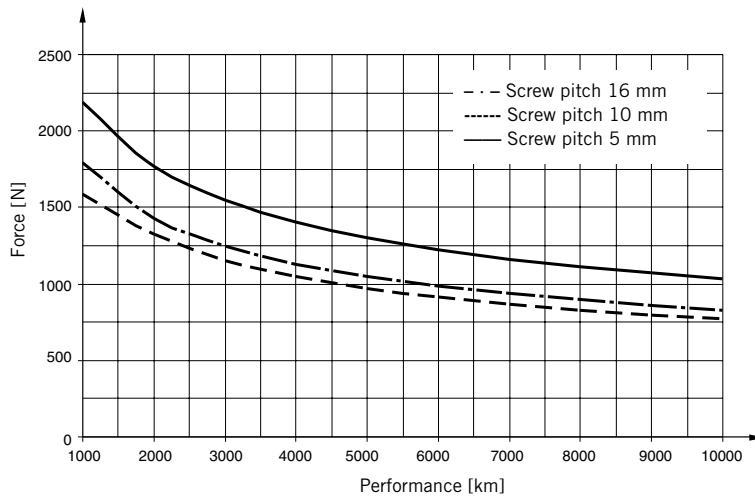

Performance subjected to thrust force requirements – size ODS-175SB

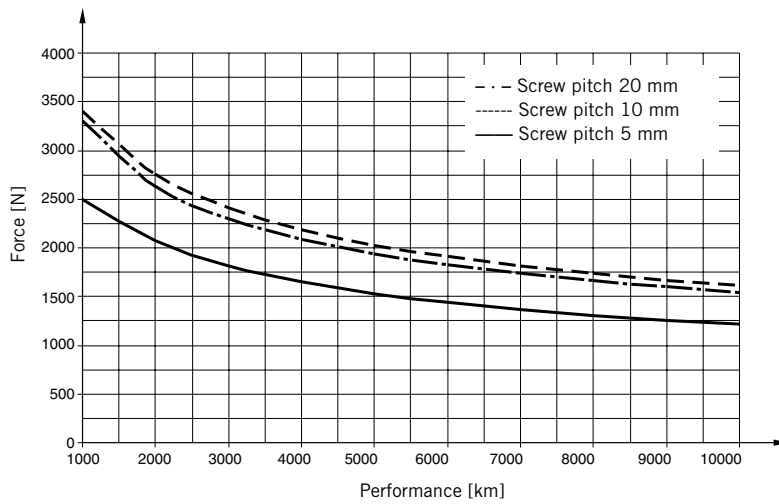

Performance subjected to thrust force requirements – size ODS-225SB

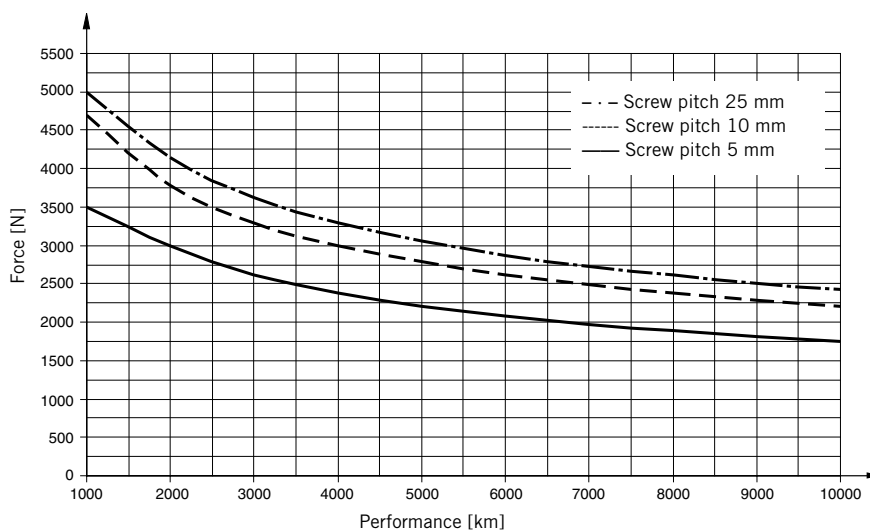

ORIGA DRIVE SYSTEM

ODS-...SB series

Ball screw

Performance

*Sizes:
145, 175, 225 mm*

Performance expectancy depends on the application's required force. An increase in force will reduce performance.

ORIGA DRIVE SYSTEM

Basic dimensions
"Basic" profile

"Reinforced" profile

ODS-...SB series

Ball screw

Dimensions

Sizes:
145, 175, 225 mm

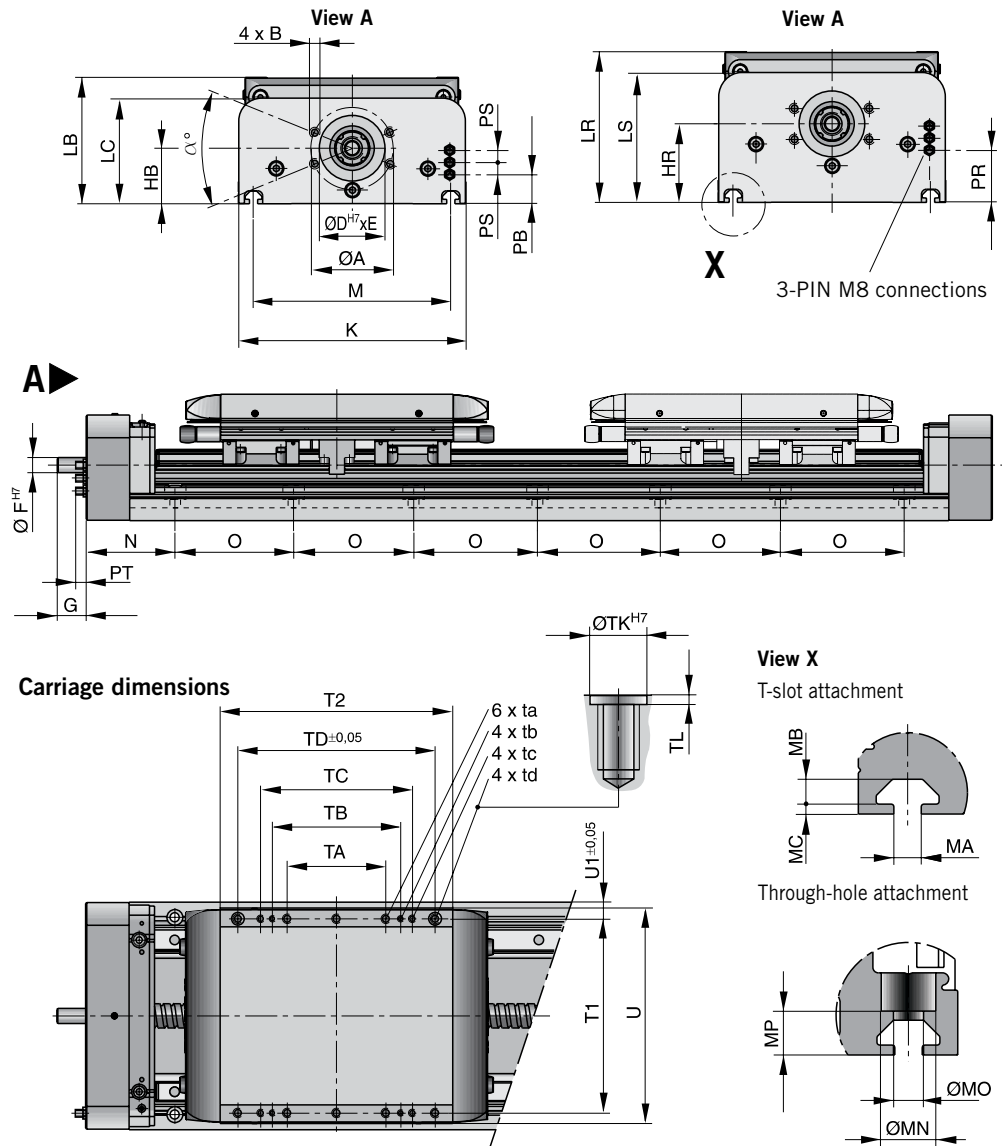

Dimension table - ODS-...SB

Type	$\varnothing A$	B	$\varnothing D^{H7}$	E	$\varnothing F^{H7}$	G	HB	HR	K	LB	LC	LR	LS
ODS-145SB	51	M6	39	4.5	10	23.5	36.0	60.0	145.0	88.0	72.0	112.0	96.0
ODS-175SB	72	M8	54	2.5	12	27.5	44.2	67.2	175.0	111.5	93.2	134.5	116.2
ODS-225SB	80	M8	64	2.5	15	28.5	55.0	83.0	225.0	125.0	104.5	153.0	133.5

Type	M	MA	MB	MC	$\varnothing MN$	$\varnothing MO$	MP	N	O	PB	PR	PS	PT	α
ODS-145SB	127.0	5.0	4.55	1.8	10.0	5.5	8.0		80.0	18.0	42.0	12.0	9.0	30°
ODS-175SB	150.0	6.2	6.75	3.0	11.0	6.6	14.0	on request	120.0	28.0	51.0	12.0	9.0	45°
ODS-225SB	195.0	8.0	8.00	4.5	15.0	9.0	15.5		120.0	29.0	57.0	12.0	9.0	45°

Dimension table - carriage ODS-...SB

Type	T1	T2	TA	ta	TB	tb	TC	tc	TD	td	$\varnothing TK^{H7}$	TL	U	U1
ODS-145SB	120	155	35	M5 x 12	-	-	87	M5 x 12	127	M5 x 12	7	1.5	135	12.5
ODS-175SB	150	170	70	M6 x 12	-	-	127	M5 x 10	150	M6 x 12	9	1.5	165	12.5
ODS-225SB	192	230	97.5	M8 x 16	127	M5 x 10	150	M6 x 12	195	M8 x 16	12	1.5	210	16.5

Dimensions in mm

ORIGA DRIVE SYSTEM

ODS series

Weight, mass and inertia

Weight, mass and inertia - ODS-...SB

Size			ODS-145SB		ODS-175SB			DS-225SB	
Version profile (B=basic / R=reinforced)			B	R	B	R	B	R	
Weight of actuator									
Weight 0 - order stroke	m_0	[kg]	2.7	3.4	5.1	6.0	8.5	10,2	
Weight per 1 m order stroke	m_{1mt}	[kg/m]	8.6	10.7	12.9	15.0	19.9	23.5	
Weight IP54 cover									
Weight 0 - order stroke	m_{0IP54}	[kg]	0.1	0.2	0.2	0.2	0.3	0.3	
Weight per 1 m order stroke	$m_{1mtIP54}$	[kg/m]	1.3	1.6	1.9	2.2	2.2	2.5	
Moving mass									
Carriage standard	m_{cs}	[kg]	1.4		2.9		6.1		
Carriage standard long	m_{csl}	[kg]	n.n		n.n		n.n		
Carriage tandem	m_{ct}	[kg]	1.1		2.3		4.7		
Carriage tandem long	m_{ctl}	[kg]	n.n.		n.n		n.n		
$m_{tot} = m_0 + m_{0IP54} + m_{cs} + OS * (m_{1mt} + m_{1mtIP54})$									

Size			ODS-145SB			ODS-175SB			DS-225SB		
Pitch			5	10	16	5	10	20	5	10	25
Inertia											
Inertia 0 - order stroke	J_0	[kgmm ²]	3			10			32		
Inertia per 1 m order stroke	J_{1mt}	[kgmm ² /m]	32			85			225		
Inertia per 1 kg moving mass	J_{1kg}	[kgmm ² /kg]	0.63	2.53	6.48	0.63	2.53	10.13	0.63	2.53	15.83
$J_{tot} = J_0 + OS * J_{1mt} + m_{car} * J_{1kg} + m_{ext} * J_{1kg}$											

ORIGA DRIVE SYSTEM

ODS-...SB series

Ball screw

Order stroke

Sizes:
145, 175, 225 mm

Order stroke dependent dimensions

S = Safety distance

J_s = Standard carriage

J_l = Long carriage

K_m = Distance between carriages (Tandem)

Standard design with one carriage

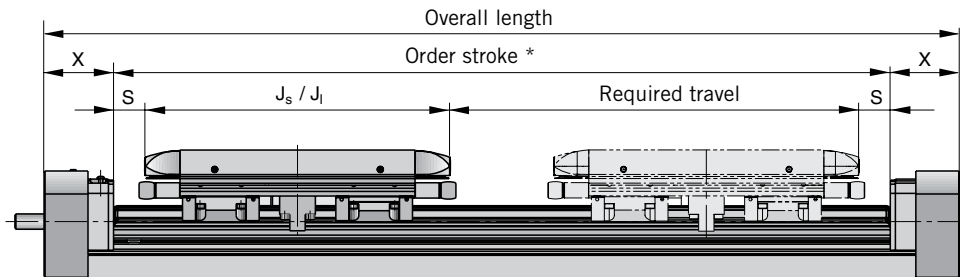

* Order stroke = required travel distance + carriage (J_s/J_l) + 2 x safety distance (S)

Tandem design with two carriages

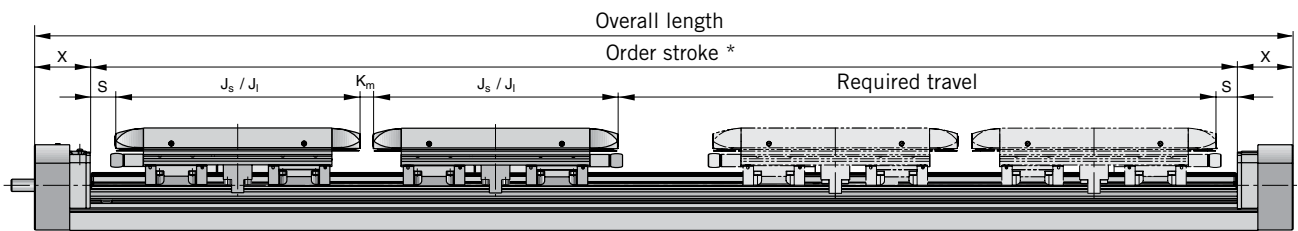

* Order stroke = required travel + 2 x carriages (J_s/J_l) + K_m + 2 x safety distance (S)

Dimension table - Carriage and over all lengths ODS-...SB

Type	J_s	J_l	X
ODS-145	230	-	50
ODS-175	250	-	58
ODS-225	310	-	68

Dimensions in mm

ORIGA DRIVE SYSTEM

ODS-...SB series

Product key ODS S3 0 B 05 P 0 - 00000 - 0 0 0 0 0 0 0

Type / size of drive	
S3	Ball screw drive / size 145
S5	Ball screw drive / size 175
S7	Ball screw drive / size 225

Profile version / mounting system	
0	Basic profile / T-slot
1	Basic profile / T-slot and standard bores
2	Basic profile / T-slot and individual bores
5	Reinforced profile / T-slot
6	Reinforced profile / T-slot and standard bores
7	Reinforced profile / T-slot and individual bores

Guide system	
B	Ball bearing guide

Pitch	
05	5 mm (sizes 145, 175, 225)
10	10 mm (sizes 145, 175, 225)
16	16 mm (size 145)
20	20 mm (size 175)
25	25 mm (size 225)

Drive shaft	
P	Plain shaft
K	Keyway

Carriage	
0	Standard
1	Tandem

Order stroke	
00000	5 digits input in mm

Protection class	
0	IP class 20
1	IP class 54 with outer cover

Impact protection	
0	Without
D	Damper

End position switch	
0	Without
1	2pc. Reed, RST-K, NC, internal
4	2pc. Electronic, EST-K, PNP internal
5	2pc. Reed, RST-S, NC, M8 plug, external
8	2pc. Electronic, EST-S, PNP, M8 plug, external

Reference switch	
0	Without
2	1pc. Reed, RST-K, NO, internal
4	1pc. Electronic, EST-K, PNP internal
6	1pc. Reed, RST-S, NO, M8 plug, external
8	1pc. Electronic, EST-S, PNP, M8 plug, external

Distance measuring system	
0	Without
1	SFI +

ODS Belt



ORIGA DRIVE SYSTEM

ODS-...B series

Belt

Drive data

Sizes

145, 175, 225 mm

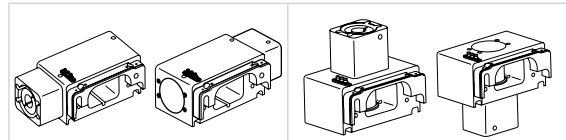

Drive data - size ODS-145B

Motor mounting position			090° / 270°	000° / 180°
Linear motion per revolution	$s_{lin.}$	[mm]	100	125
Max. speed	$v_{max.}$	[m/s]	3	3
Max. acceleration	$a_{max.}$	[m/s ²]	50	50
Max. thrust force	$F_{A max.}$	[N]	1,050	630
Max. torque	$M_{A max.}$	[Nm]	17	13
No load torque	M_0	[Nm]	1.1	1.3
Repeatability		[mm]	± 0.05	± 0.05
Max. order stroke		[mm]	6,000	6,000

Drive data - size ODS-175B

Motor mounting position			090° / 270°	000° / 180°
Linear motion per revolution	$s_{lin.}$	[mm]	130	150
Max. speed	$v_{max.}$	[m/s]	5	5
Max. acceleration	$a_{max.}$	[m/s ²]	50	50
Max. thrust force	$F_{A max.}$	[N]	1,300	1,100
Max. torque	$M_{A max.}$	[Nm]	27	24
No load torque	M_0	[Nm]	1.9	2.2
Repeatability		[mm]	± 0.05	± 0.05
Max. order stroke		[mm]	6,000	6,000

Drive data - size ODS-225B

Motor mounting position			090° / 270°	000° / 180°
Linear motion per revolution	$s_{lin.}$	[mm]	160	224
Max. speed	$v_{max.}$	[m/s]	5	5
Max. acceleration	$a_{max.}$	[m/s ²]	50	50
Max. thrust force	$F_{A max.}$	[N]	3,750	3,750
Max. torque	$M_{A max.}$	[Nm]	117	134
No load torque	M_0	[Nm]	3.6	4.1
Repeatability		[mm]	± 0.05	± 0.05
Max. order stroke		[mm]	4,000	4,000

ORIGA DRIVE SYSTEM

ODS-...B series

Belt

Thrust forces

*Sizes
145, 175, 225 mm*

Valid action forces - size ODS-145B

Version motor mounting position		090°/270°	000°/180°
Speed			
Thrust force F corresponding to speed v	$F_{v < 1}$	[N]	1,050
	$F_{v < 3}$	[N]	936
	$F_{v < 5}$	[N]	-
Order stroke			
Thrust force F corresponding to order stroke length OS	$F_{OS < 1000}$	[N]	1,050
	$F_{OS < 2000}$	[N]	880
	$F_{OS < 3000}$	[N]	628
	$F_{OS < 4000}$	[N]	471

Valid action forces - size ODS-175B

Version motor mounting position		090°/270°	000°/180°
Speed			
Thrust force F corresponding to speed v	$F_{v < 1}$	[N]	1,300
	$F_{v < 3}$	[N]	1,300
	$F_{v < 5}$	[N]	1,300
Order stroke			
Thrust force F corresponding to order stroke length OS	$F_{OS < 1000}$	[N]	1,300
	$F_{OS < 2000}$	[N]	1,088
	$F_{OS < 3000}$	[N]	773
	$F_{OS < 4000}$	[N]	604

The maximum permissible thrust force is depending on speed level and order stroke lengths shown in table beside. The lowest value in comparison must not be exceeded.

Information:
Torque limitation of the drive avoids exceeded forces in the application.

Valid action forces - size ODS-225B

Version motor mounting position		090°/270°	000°/180°
Speed			
Thrust force F corresponding to speed v	$F_{v < 1}$	[N]	3,750
	$F_{v < 3}$	[N]	3,656
	$F_{v < 5}$	[N]	3,206
Order stroke			
Thrust force F corresponding to order stroke length OS	$F_{OS < 1000}$	[N]	3,750
	$F_{OS < 2000}$	[N]	3,750
	$F_{OS < 3000}$	[N]	3,377
	$F_{OS < 4000}$	[N]	2,395

Example

ODS-175B with motor mounting position 090°, speed $v = 2$ m/s ($F = 1,300$ N) and order stroke $OS = 2,500$ mm ($F = 773$ N).

The maximum permitted action force of $F = 773$ N must not be exceeded.

ORIGA DRIVE SYSTEM

ODS-...B series

Belt

Dimensions

Sizes

145, 175, 225 mm

Basic dimensions

"Basic" profile

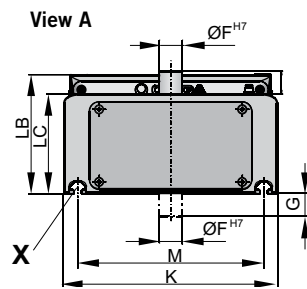

"Reinforced" profile

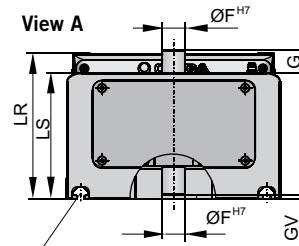

View B

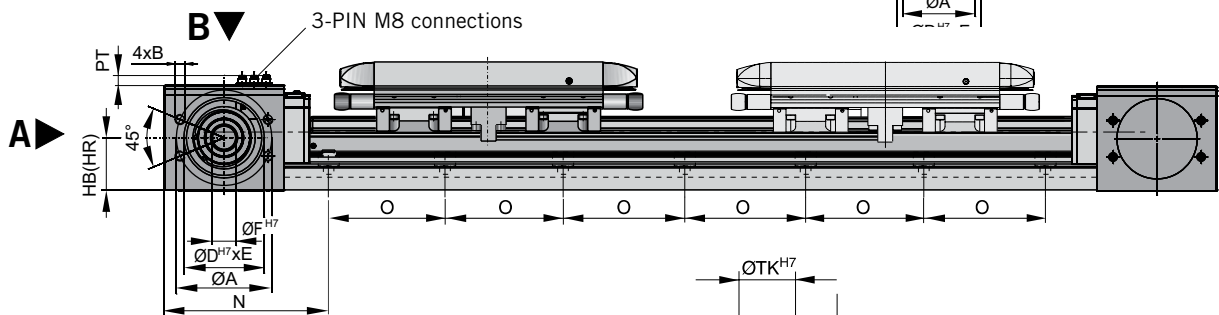
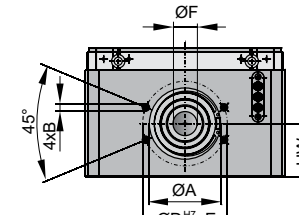

Carriage dimensions

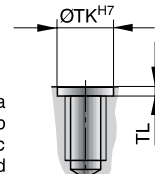
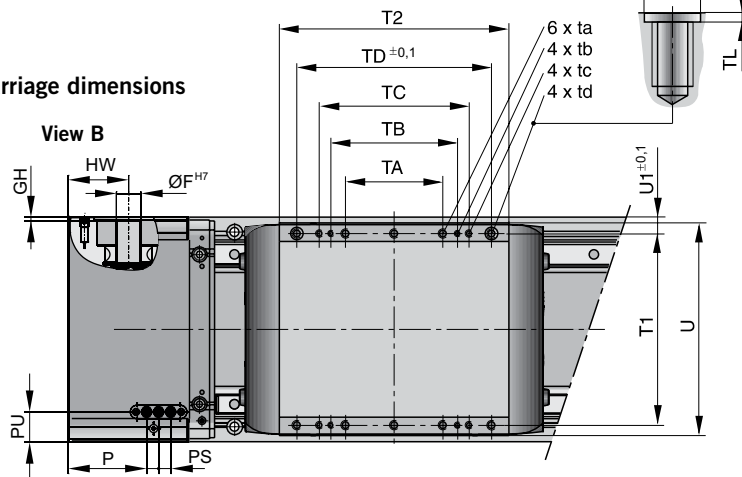

View X

T-slot attachment

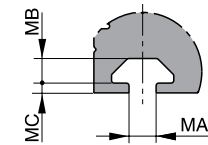

Through-hole attachment

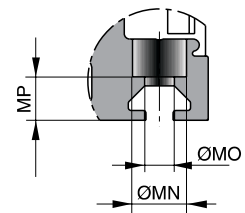

Dimension table - ODS-...B

Size	ØA	B	ØD ^{H7}	E	ØF ^{H7}	G	GV	GH	HB	HR	HW	K	LB	LC	LR	LS
ODS-145B	72	M8	54	2.5	15	24.0	5.0	3.0	34.5	58.5	45.0	145.0	88.0	72.0	112.0	96.0
ODS-175B	80	M8	64	2.5	18	22.0	1.8	5.5	45.0	68.0	50.0	175.0	111.5	93.2	134.5	116.2
ODS-225B	95	M10	80	2.5	24	19.0	4.0	3.5	52.5	80.5	60.0	225.0	125.0	104.5	153.0	133.5

Size	M	MA	MB	MC	ØMN	ØMO	MP	N	O	P	PS	PT	PU
ODS-145B	127	5	4.55	1.8	10	5.5	8.0		80.0	48.0	12.0	9.0	21.0
ODS-175B	150	6.2	6.75	3.0	11	6.6	14.0	on request	120.0	58.0	12.0	9.0	28.0
ODS-225B	195	8	8	4.5	15	9.0	15.5		120.0	78.0	12.0	9.0	30.0

Dimension table - Carriage ODS-...B

Size	T1	T2	TA	ta	TB	tb	TC	tc	TD	td	ØTK ^{H7}	TL	U	U1
ODS-145B	120	155	35	M5 x 12	-	-	87	M5 x 12	127.0	M5 x 12	7.0	1.5	135.0	12.5
ODS-175B	150	170	70	M6 x 12	-	-	127	M5 x 10	150.0	M6 x 12	9.0	1.5	165.0	12.5
ODS-225B	192	230	97.5	M8 x 16	127	M5 x 10	150	M6 x 12	195.0	M8 x 16	12.0	1.5	210.0	16.5

ORIGA DRIVE SYSTEM

Series ODS
Weight, mass, inertia

Weight, mass and inertia - ODS-... B

Series			ODS-145B		ODS-175B		DS-225B	
Version profile (B=basic / R=reinforced)			B	R	B	R	B	R
Weight of actuator								
Weight 0 - order stroke	m_0	[kg]	4.7	6.0	7.6	9.4	14.3	17.6
Weight per 1 m order stroke	m_{1mt}	[kg/m]	7.4	9.5	11.1	13.2	17.7	21.3
Weight IP54 cover								
Weight 0 - order stroke	m_{0IP54}	[kg]	0.1	0.2	0.2	0.2	0.3	0.3
Weight per 1 m order stroke	$m_{1mtIP54}$	[kg/m]	1.3	1.6	1.9	2.2	2.2	2.5
Moving mass								
Carriage standard	m_{cs}	[kg]	1.6		2.6		6.5	
Carriage standard long	m_{csl}	[kg]	n.n		n.n		n.n	
Carriage tandem	m_{ct}	[kg]	1.1		2.3		4.7	
Carriage tandem long	m_{ctl}	[kg]	n.n.		n.n		n.n	
$m_{tot} = m_0 + m_{0IP54} + m_{cs} + OS * (m_{1mt} + m_{1mtIP54})$								

Series			ODS-145B		ODS-175B		DS-225B	
Motor mounting position			090°/ 270°	000°/ 180°	090°/ 270°	000°/ 180°	090°/ 270°	000°/ 180°
Inertia								
Inertia 0 - order stroke	J_0	[kgmm ²]	111	168	342	454	1,274	2,857
Inertia pro 1 m order stroke	J_{1mt}	[kgmm ² /m]	79	79	167	178	641	839
Inertia pro 1 kg moving mass	J_{1kg}	[kgmm ² /kg]	253	396	428	570	648	1,271
$J_{tot} = J_0 + OS * J_{1mt} + m_{car} * J_{1kg} + m_{ext} * J_{1kg}$								

ORIGA DRIVE SYSTEM

ODS-...B series

Belt

Order stroke

Sizes

145, 175, 225 mm

Order stroke dependent dimensions

S = Safety distance

J_s = Standard carriage

J_l = Long carriage

K_m = Distance between carriages (Tandem / Bi-parting)

Standard design with one carriage

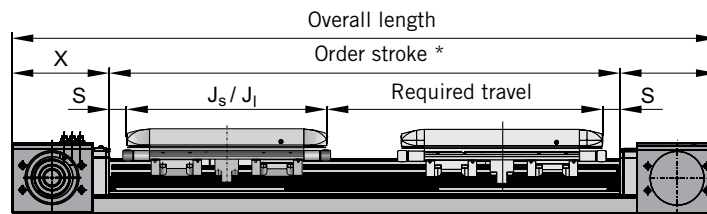

* Order stroke = required travel distance + carriage (J_s/J_l) + 2 x safety distance (S)

Tandem design with two carriages

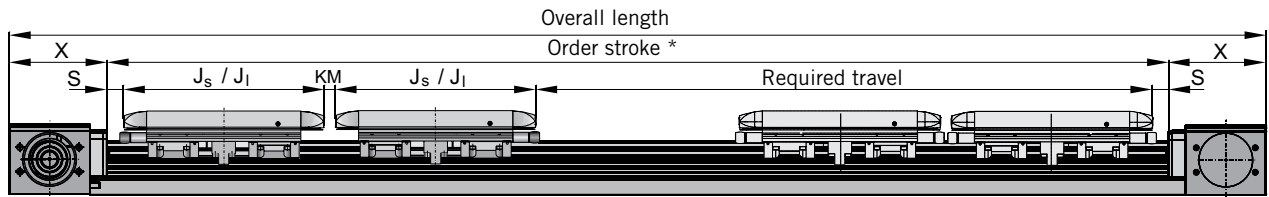

* Order stroke = required travel distance + 2 x carriages (J_s/J_l) + K_m + 2 x safety distance (S)

Bi-parting design with two carriages for opposite movements

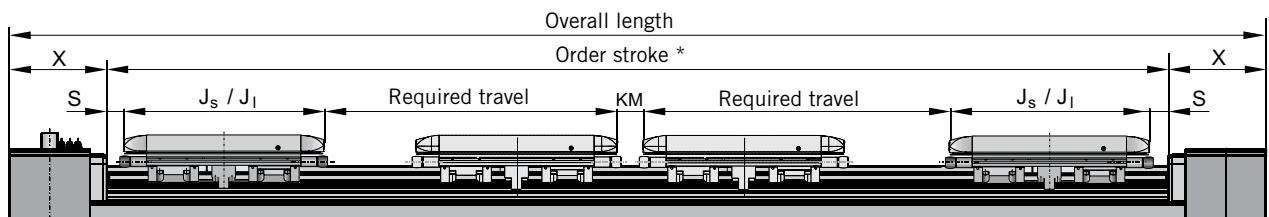

* Order stroke = 2x required travel + 2x carriages (J_s/J_l) + K_m + 2 x safety distance (S)

Dimension table - Carriage and overall length ODS-...B

Size	J_s	J_l	X
ODS-145B	230	–	110
ODS-175B	250	–	120
ODS-225B	310	–	142

Dimensions in mm

ORIGA DRIVE SYSTEM

ODS-...B series

Product key ODS B3 0 B 0 0 D 0 - 00000 - 0 0 0 0 0 0 0 0

Type / size of drive	
B3	Belt positioner / size 145
B5	Belt positioner / size 175
B7	Belt positioner / size 225

Profile version / mounting system	
0	Basic profile / T-slot
1	Basic profile / T-slot and standard bores
2	Basic profile / T-slot and individual bores
5	Reinforced profile / T-slot
6	Reinforced profile / T-slot and standard bores
7	Reinforced profile / T-slot and individual bores

Guide system	
B	Ball bearing guide

Motor mounting position	
0	090° front
1	270° back
2	000° up
3	180° down

Drive shaft	
D	Double plain shaft
P *	Plain shaft

Carriage	
0	Standard
1	Tandem
2 *	Bi-parting

Order stroke	
00000	5 digits input in mm

Protection class	
0	IP class 20
1	IP class 54 with outer cover

Impact protection	
0	Without
D	Damper

Magnetic end position switch	
0	Without
1	2pc. Reed, RST-K, NC (normally closed), internal
4	2pc. electronic, EST-K, PNP, internal
5	2pc. Reed, RST-S, NC, M8-plug, external
8	2pc. electronic, EST-S, PNP, M8-plug, external

Magnetic reference switch	
0	Without
2	1pc. Reed, RST-K, NO (normally open), internal
4	1pc. Electronic, EST-K, PNP, internal
6	1pc. Reed, RST-S, NO, M8-plug, external
8	1pc. Electronic, EST-S, PNP, M8-plug, external

* only at motor mounting position 2 (000° = up) and 3 (180° = down)

ODS Options



ORIGA DRIVE SYSTEM

ODS series

Option

Protection class

Versions:

IP20 – without cover

IP54 – with cover

ODS got developed for various environment conditions. The basic ODS design has an IP20 protection class. ODS can be equipped with a cover to correspond to an IP54 protection class if a higher rating is required.

Version – IP20 protection class



Version – IP54 protection class



Shock absorbers for impact protection

Type	Shock absorber	Energy absorption (Nm/stroke)	Maximum stroke (mm)
ODS-145	TA12-5	3.0	5.0
ODS-175	TA17-7	8.5	7.0
ODS-225	TA17-7	8.5	7.0

ORIGA DRIVE SYSTEM

ODS series

Option

Impact protection

Distance-force and energy-distance characteristic curve (dynamic) – Size ODS-145

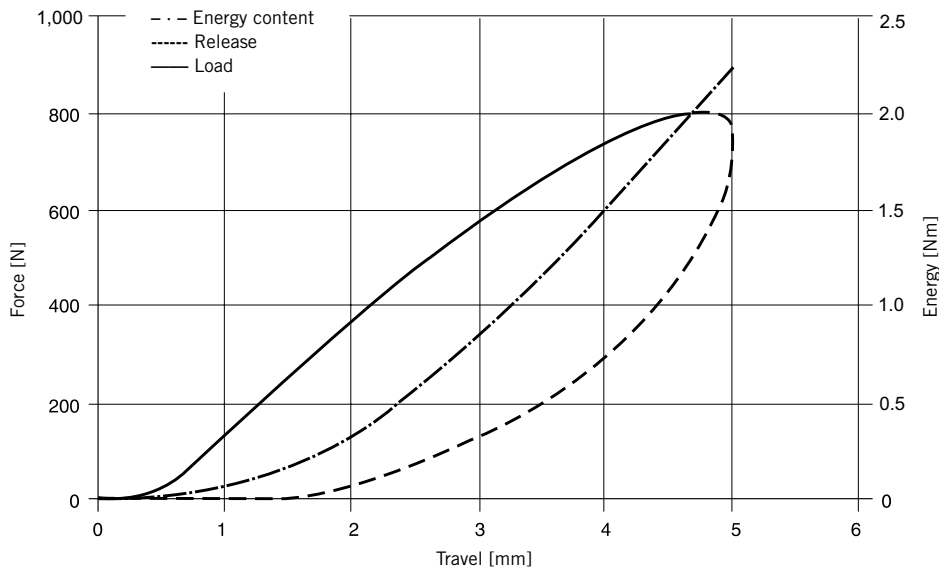

Distance-force and energy-distance characteristic curve (dynamic) – Size ODS-175, ODS-225

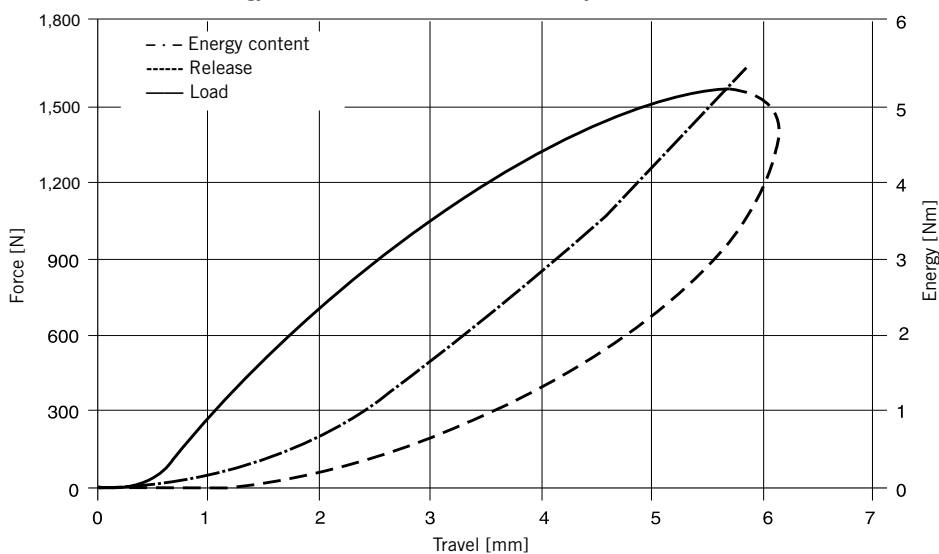

ODS can be equipped with impact protection. The mounted structure shock absorbers can compensate the energy released by unintentional impact and afford protection against mechanical damage.

Two structure shock absorbers are fitted to each side of the carriage prior to delivery.



ORIGA DRIVE SYSTEM

ODS series

Option

Position detection

Magnetic switches for:

–End positions

–Homing

Magnetic switches, for instance in the end positions, are required to electronically detect the carriage position. They can also be used to detect the homing position.

Magnets built in as standard provide contactless sensing. A yellow LED indicates the operating status.

Electrical specifications

Description	Symbol	Unit	Comments	
Output function				
Switch output			Reed	PNP / NPN
Output function			NC (normally closed) NO (normally open)	NO (normally open)
Connection type			2-core	3-core
Protective circuit			Pin 1 = + V (br) Pin 3 = Signal (bl)	Pin 1 = + V (br) Pin 3 = 0 V (bl) Pin 4 = Signal (sw/we)
Display			LED yellow	LED yellow
Electrical properties				
Operating voltage	U_n	V	10–30 AC/DC	10–30 DC
Voltage drop	U_d	V	≤ 3	≤ 2
Permanent current	I_n	mA	≤ 100	≤ 100
Current consumption	I_{on}	mA	–	≤ 10
Switching capacity	P_s	W	≤ 6 peak	–
Switchable capacity	C_s	nF	100 (100Ω, 24VDC)	100 (100Ω, 24VDC)
Switching frequency	f_s	Hz	≤ 400	≤ 5000
Switching time (On/Off)	t_{10}	ms	≤ 2	≤ 2
Sensitivity		mT	2–4	2–4
Switch-point accuracy		mm	≤ 0.2	≤ 0.2
Hysteresis		mm	≤ 1.5	≤ 1.5
EMV			EN 60947-5-2	EN 60947-5-2
Service life			35 million cycles	unlimited
Short-circuit protection			–	Yes
Reverse polarity protection			Yes	Yes
Mechanical specifications				
Connection cable			PUR, black	PUR, black
Cable cross-section		mm ²	2 x 0.14	3 x 0.14
Connector plug			M8, 3-pole	M8, 3-pole
Housing			Plastic, red, PA66 + PA6I	Plastic, red, PA66 + PA6I
Weight	m	g	10	10
Ambient conditions				
Protection class (EN 60529)			IP 67	IP 67
Temperature range *	ΔT	°C	-25 to +80	-25 to +75 (10–30V) -25 to +80 (10–28V)
Vibration (EN 60068-2-6)		G	15 (11 ms, 10–55 Hz, 1 mm)	15 (11 ms, 10–55 Hz, 1 mm)
Shock (EN 60068-2-27)		G	50 (11 ms)	50 (11 ms)
Permanent shock (EN 60068-2-29)		G	30 (11 ms, 1000 shocks)	30 (11 ms, 1000 shocks)

* Please observe the surface temperature and self-heating action of the drive in relation to the temperature ranges of magnetic switch sets.

$$\text{Minimum response time} = \frac{\text{Contact travel}}{\text{Overrun speed}}$$



Information:

The possible speed of the load-bearing element or carriage must take the minimum response time of downstream devices into account. Contact travel is considered accordingly in the calculations.

RST-S and EST-S magnetic switches

Electrical performance life, protection measures

Magnetic switch sets are sensitive to excessive voltage loads and inductions. Their service life is greatly reduced by high switching frequencies with inductive loads such as relays, magnetic valves or stroke magnets.

Ohmic and capacitive loads with a high switching current such as light bulbs, should have protective resistance connected in series with the load. The same applies to long lengths of cable. Load peaks (transients) occur when switching inductive loads such as relays, magnetic valves and stroke magnets, and should be suppressed by means of protective diodes, RC circuits or varistors.

Connection examples:

- Load with protective circuits
- (a) Series resistor to the light bulb
- (b) Free-wheeling diode to inductivity
- (c) Varistor to inductivity
- (d) RC member to inductivity

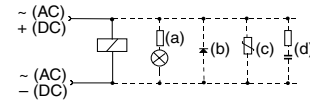

External protective circuits for Type EST are not usually required.

ORIGA DRIVE SYSTEM

ODS series

Option

Position detection

Magnetic switches

- End positions

- Homing

Electrical connection type RST-S

Reed, normally closed

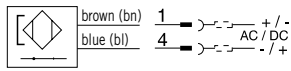

Reed, normally open

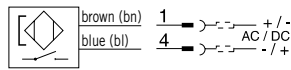

Electrical connection type EST-S

NPN, normally closed

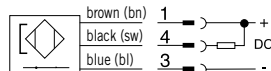

NPN, normally open

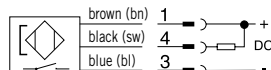

PNP, normally closed

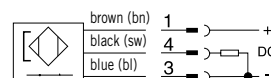

PNP, normally open



RST-S

The RST-S type makes low-impact contact via a mechanical reed switch encapsulated in glass.

EST-S

The EST-S type protects against reverse polarity and makes non-impact and wear-free contact via an electronic switch. The output is protected against short circuiting and resistant to shocks and vibrations.

Dimensions – RST-S and EST-S

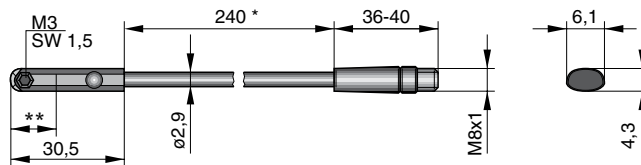

* ± 6 mm

** switching point:

Type RST-S NC	14 mm
Type RST-S NO	12.3 mm
Type EST-S NC	8.1 mm
Type EST-S NO	8.1 mm

Magnet switches designations



M8 connectors at ODS...SB

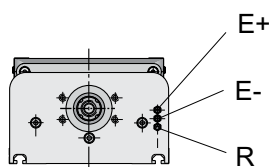

M8 connectors at ODS...B

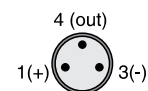
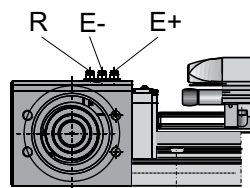

PIN configuration (top view) in accordance with DIN EN 50044

Connecting cable suitable for cable chain

KL3186	M8 connector, 5m cable
KL3217	M8 connector, 10m cable
KL3216	M8 connector, 15m cable



ORIGA DRIVE SYSTEM

ODS series

Option

Distance measuring

Version SFI-plus

The contact-free magnetic displacement measuring system provides a standard resolution of 0.1 mm (higher resolutions available on request).

The position of the stationary or moving carriage is detected directly and processed by the corresponding controller (e.g. SPS, PC) on the basis of incremental signals.

Specifications

Specifications	Unit	Comments
Type		21210
Output function		
Resolution	mm	0.1
Pole length of measuring tape	mm	5
Max. speed	m/s	10
Repeat accuracy		± 1 increment
Distance sensor/measuring tape	mm	≤ 4
Sensor head incline		≤ 5°
Potential lateral deviation	mm	≤ ± 1.5
Switch output		PNP
Electrical characteristics		
Operating voltage U_b	V DC	18–30
Voltage drop	V	≤ 2
Permanent current per output	mA	≤ 20
Current consumption at $U_b = 24$ V, activated, no load	mA	≤ 50
Short-circuit protection		Yes
Reverse polarity protection		Yes
Protection against inductive switch-off peaks		Yes
Turn-on pulse suppression		Yes
EMV		
Electro-static discharge	kV	6, B, i a w EN 61000-4-2
Electro-magnetic field	V/m	10, A, i a w EN 61000-4-3
Rapid Transient Burst (signal connections)	kV	1, B, i a w EN 61000-4-4
Rapid Transient Burst (DC connections)	kV	2, B, i a w EN 61000-4-4
Surge voltage strength (signal connections)	kV	1, B, i a w EN 61000-4-5
Surge voltage strength (DC-connections)	kV	0.5, B, i a w EN 61000-4-5
HF conducted	V	10, A, i a w EN 61000-4-6
Magnetic field at 50 Hz	A/m	30, A, i a w EN 61000-4-8
Interference transmission		i a w EN 61000-6-4
Emitted interference transmission		i a w EN 55011, Group 1, A
Mechanical specifications		
Housing		Aluminum
Cable length	m	5.0 – cast-on, open-ended
Cable cross-section	mm ²	4 x 0.14
Cable design		PUR, black
Bending radius	mm	≥ 36
Weight (mass)	kg	approx. 0.165
Ambient conditions/shock resistance		
Protection class	IP	67 i a w EN 60529
Ambient temperature range	°C	-25 to +80
Broadband noise i a w EN 60068-2-64	g	5.5 Hz to 2 kHz, 0.5 h per axis
Vibration i a w EN 60068-2-6	g	12, 10 Hz to 2 kHz, 2 mm, 5 h per axis
Shock i a w EN 60068-2-27	g	100.6 ms, 50 shocks per axis
Permanent shocks i a w EN 60068-2-29	g	5.2 ms, 8,000 shocks per axis



Signal course – sensing head output



Dimensions – sensing head

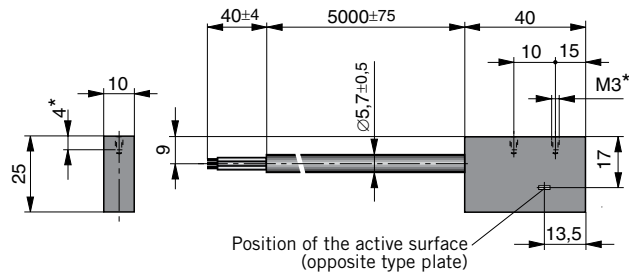

* Screw-in depth max. 4 mm

ORIGA DRIVE SYSTEM

ODS series

Option

Distance measuring

Version SFI-plus

Sensing head

The sensing head transmits two pulsed counting signals (Phase A and B) with phases offset by 90° and a resolution of 0.4 mm (optional: 4 mm). The resolution can be increased to 0.1 mm (optional: 1 mm) through edge evaluation. The counting direction results automatically from the phase displacement of the counting signals.

Electrical connection

Color	Description
bn = brown	+ DC
bl = blue	- DC
sw = black	Phase A
ws = white	Phase B

Dimensions in mm



ODS Accessories



ORIGA DRIVE SYSTEM

Series ODS

Accessories

Coupling housing

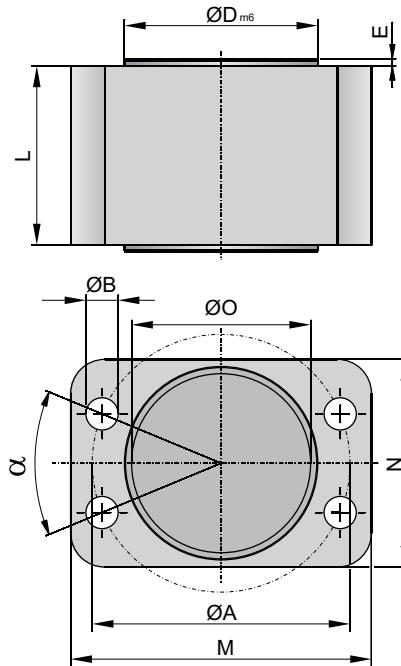

Ball screw

Dimension table coupling housing ODS-...SB

Size	$\varnothing A$	$\varnothing B$	$\varnothing D_{m6}$	E	$\varnothing O$	L	M	N	α	Order No.
ODS-145SB	51	6.6	39	2	35	38	62	43	30°	50055
ODS-175SB	72	9.0	54	2	50	54	84	58	45°	50353
ODS-225SB	80	9.0	64	2	60	70	90	68	45°	50655

Belt

Dimension table coupling housing short ODS-...B

Size	$\varnothing A$	$\varnothing B$	$\varnothing D_{m6}$	E	$\varnothing O$	L	M	N	α	Order No.
ODS-145B	72	9.0	54	2	50	30	84	58	45°	56412
ODS-175B	80	9.0	64	2	60	42	90	68	45°	56413
ODS-225B	95	11.0	80	2	77	60	107	85	45°	56414

- At motor mounting position 090° and 270°
- Choose the long coupling housing, when the motor mounting position 180° is and profile version „basic“ got selected.

Dimension table coupling housing long ODS-...B

Size	$\varnothing A$	$\varnothing B$	$\varnothing D_{m6}$	E	$\varnothing O$	L	M	N	α	Order No.
ODS-145B	72	9.0	54	2	50	54	84	58	45°	50353
ODS-175B	80	9.0	64	2	60	70	90	68	45°	50655
ODS-225B	95	11.0	80	2	77	85	107	85	45°	56415

- At motor mounting position 000° and 180°
- Choose the short coupling housing, when the motor mounting position 180° is and profile version "reinforced" got selected.



Dimensions in mm

ORIGA DRIVE SYSTEM

Series ODS

Accessories

Motor coupling

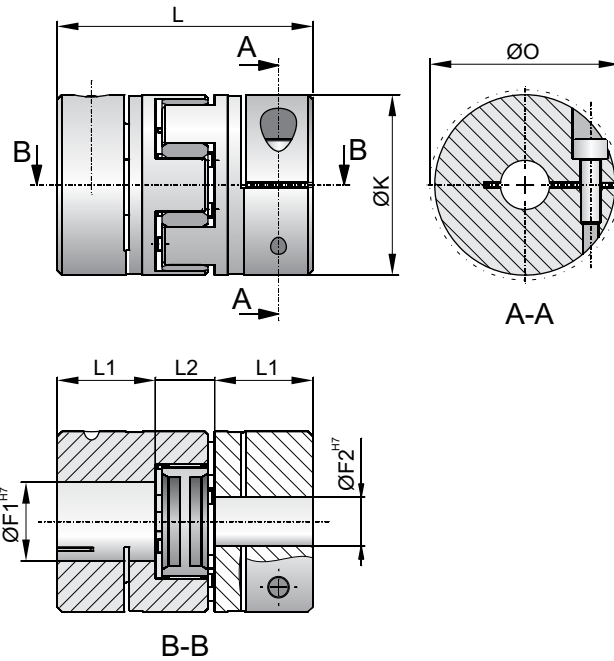

Ball screw

Dimension table motor coupling ODS...SB

Size	$\varnothing F_1^{H7}$	$\varnothing F_2^{H7}$	$\varnothing F^*$	$\varnothing K$	L	L_1	L_2	$\varnothing 0$	Order No.
ODS-145SB	10	5	5 - 16	30	35	11	13	32.2	15590
ODS-175SB	12	9	8 - 24	40	66	25	16	46.0	56400
ODS-225SB	15	14	10 - 28	55	78	30	18	58.0	56402

Belt

Dimension table motor coupling ODS...B

Size	$\varnothing F_1^{H7}$	$\varnothing F_2^{H7}$	$\varnothing F^*$	$\varnothing K$	L	L_1	L_2	$\varnothing 0$	Order No.
ODS-145B	15	10	8 - 24	40	66	25	16	46.0	16239
ODS-175B	18	14	10 - 28	55	78	30	18	58.0	56411
ODS-225B	24	15	14 - 38	65	90	35	20	73.0	16260

* Possible bore diameter



Dimensions in mm

ORIGA DRIVE SYSTEM

Series ODS

Accessories

T-Slot mountings

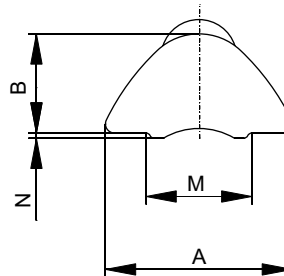
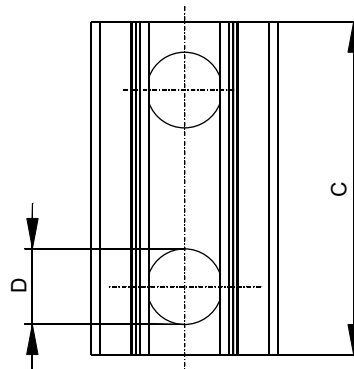

Dimension table T-slot mounting ODS

Size	A	B	C	ØD	M	N	Order-No.
ODS-145	9.0	4.0	11.5	M5	5.0	0.5	56351
ODS-175	10.6	6.2	22.0	M6	7.0	0.7	56352
ODS-225	13.8	7.3	23.0	M8	8.5	1.0	56353

* Packing unit 10 pc.



Dimensions in mm

Drive Combinations

Ball Screw Drive





Type of drive		Coupling housing	Motor coupling	Motor flange
ODS-145SB		50055	12074	51533
			10801	56410
ODS-175SB		50353	16866	50358
			56401	56433
ODS-225SB		50655	56403	50660
			56404	56435
			56404	56435

Belt Drive



Type of drive	Profile version	Motor mounting position	Example	Coupling housing	Motor coupling	Motor flange
ODS-145B	every	0 = 090° front	ODSB3xx0...	56412	15227	56423
		1 = 270° back	ODSB3xx1...			
	0, 1, 2 = Basis	2 = 000° up	ODSB30x2...	50353		
	0, 1, 2 = Basis	3 = 180° down	ODSB30x3...			
	5, 6, 7 = Reinforced	2 = 000° up	ODSB35x2...	56412		
5, 6, 7 = Reinforced	3 = 180° down	ODSB35x3...				
ODS-175B	every	0 = 090° front	ODSB5xx0...	56413	56419	56425
		1 = 270° back	ODSB5xx1...			
	0, 1, 2 = Basis	2 = 000° up	ODSB50x2...	50655		
	0, 1, 2 = Basis	3 = 180° down	ODSB50x3...			
	5, 6, 7 = Reinforced	2 = 000° up	ODSB55x2...	56413		
5, 6, 7 = Reinforced	3 = 180° down	ODSB55x3...				
ODS-225B	every	0 = 090° front	ODSB7xx0...	56414	56416	56427
		1 = 270° back	ODSB7xx1...			
	0, 1, 2 = Basis	2 = 000° up	ODSB70x2...	56415		
	0, 1, 2 = Basis	3 = 180° down	ODSB70x3...			
	5, 6, 7 = Reinforced	2 = 000° up	ODSB75x2...	56414		
5, 6, 7 = Reinforced	3 = 180° down	ODSB75x3...				

						
	Servo motor	Motor cable	Resolver cable	Controller	Connector kit	
	SMH60 60 1,4 8 11 S 2ID 65 4	MOK54/03	REK41/03	C3S 015 V4 F10 I11 T11 M00	ZBH02/02	
	SMH82 60 03 8 14 S 2ID 65 4	MOK54/03	REK41/03	C3S 038 V4 F10 I11 T11 M00		
	SMH82 60 03 8 14 S 2ID 65 4	MOK54/03	REK41/03	C3S 038 V4 F10 I11 T11 M00	ZBH02/02	
	SMH100 56 06 5 19 S 2ID 65 4	MOK54/03	REK41/03	C3S 075 V4 F10 I11 T11 M00		
	SMH100 56 06 5 19 S 2ID 65 4	MOK54/03	REK41/03	C3S 075 V4 F10 I11 T11 M00	ZBH02/02	
	SMH115 56 10 5 24 S 2I 65 4	MOK57/03	REK41/03	C3S 150 V4 F10 I11 T11 M00		
	SMH142 56 15 5 24 S 2I 65 4	MOK57/03	REK41/03	C3S 150 V4 F10 I11 T11 M00		

						
Gear	Mounting kit	Servo motor	Motor cable	Resolver cable	Controller	Connector kit
PS60-xxx-S2 RS60-xxx-S2	MU60-254	SMH60 60 1,4 8 11 S 2ID 65 4	MOK54/03	REK41/03	C3S 015 V4 F10 I11 T11 M00	ZBH02/02
PS60-xxx-S2 RS60-xxx-S2		SMH82 60 03 8 14 S 2ID 65 4	MOK54/03	REK41/03	C3S 038 V4 F10 I11 T11 M00	
PS90-xxx-S2 RS90-xxx-S2	MU90-001	SMH82 60 03 8 14 S 2ID 65 4	MOK54/03	REK41/03	C3S 038 V4 F10 I11 T11 M00	ZBH02/02
PS90-xxx-S2 RS90-xxx-S2	MU90-088	SMH100 56 06 5 19 S 2ID 65 4	MOK54/03	REK41/03	C3S 075 V4 F10 I11 T11 M00	
PS115-xxx-S2 RS115-xxx-S2	MU115-270	SMH100 56 06 5 19 S 2ID 65 4	MOK54/03	REK41/03	C3S 075 V4 F10 I11 T11 M00	ZBH02/02
PS115-xxx-S2 RS115-xxx-S2	MU115-026	SMH115 56 10 5 24 S 2I 65 4	MOK57/03	REK41/03	C3S 150 V4 F10 I11 T11 M00	

Information:
The SMH motors can be also equipped with an absolut multiturn encoder and/or holding brake for vertical applications.
Shown cables are with 5 meter cable length. Other lengths on request.

Parker Worldwide

Europe, Middle East, Africa

AE – United Arab Emirates, Dubai
Tel: +971 4 8127100
parker.me@parker.com

AT – Austria, Wiener Neustadt
Tel: +43 (0)2622 23501-0
parker.austria@parker.com

AT – Eastern Europe, Wiener Neustadt
Tel: +43 (0)2622 23501 900
parker.easteurope@parker.com

AZ – Azerbaijan, Baku
Tel: +994 50 2233 458
parker.azerbaijan@parker.com

BE/LU – Belgium, Nivelles
Tel: +32 (0)67 280 900
parker.belgium@parker.com

BY – Belarus, Minsk
Tel: +375 17 209 9399
parker.belarus@parker.com

CH – Switzerland, Etoy
Tel: +41 (0)21 821 87 00
parker.switzerland@parker.com

CZ – Czech Republic, Klecany
Tel: +420 284 083 111
parker.czechrepublic@parker.com

DE – Germany, Kaarst
Tel: +49 (0)2131 4016 0
parker.germany@parker.com

DK – Denmark, Ballerup
Tel: +45 43 56 04 00
parker.denmark@parker.com

ES – Spain, Madrid
Tel: +34 902 330 001
parker.spain@parker.com

FI – Finland, Vantaa
Tel: +358 (0)20 753 2500
parker.finland@parker.com

FR – France, Contamine s/Arve
Tel: +33 (0)4 50 25 80 25
parker.france@parker.com

GR – Greece, Athens
Tel: +30 210 933 6450
parker.greece@parker.com

HU – Hungary, Budapest
Tel: +36 1 220 4155
parker.hungary@parker.com

IE – Ireland, Dublin
Tel: +353 (0)1 466 6370
parker.ireland@parker.com

IT – Italy, Corsico (MI)
Tel: +39 02 45 19 21
parker.italy@parker.com

KZ – Kazakhstan, Almaty
Tel: +7 7272 505 800
parker.easteurope@parker.com

NL – The Netherlands, Oldenzaal
Tel: +31 (0)541 585 000
parker.nl@parker.com

NO – Norway, Asker
Tel: +47 66 75 34 00
parker.norway@parker.com

PL – Poland, Warsaw
Tel: +48 (0)22 573 24 00
parker.poland@parker.com

PT – Portugal, Leca da Palmeira
Tel: +351 22 999 7360
parker.portugal@parker.com

RO – Romania, Bucharest
Tel: +40 21 252 1382
parker.romania@parker.com

RU – Russia, Moscow
Tel: +7 495 645-2156
parker.russia@parker.com

SE – Sweden, Spånga
Tel: +46 (0)8 59 79 50 00
parker.sweden@parker.com

SK – Slovakia, Banská Bystrica
Tel: +421 484 162 252
parker.slovakia@parker.com

SL – Slovenia, Novo Mesto
Tel: +386 7 337 6650
parker.slovenia@parker.com

TR – Turkey, Istanbul
Tel: +90 216 4997081
parker.turkey@parker.com

UA – Ukraine, Kiev
Tel: +380 44 494 2731
parker.ukraine@parker.com

UK – United Kingdom, Warwick
Tel: +44 (0)1926 317 878
parker.uk@parker.com

ZA – South Africa, Kempton Park
Tel: +27 (0)11 961 0700
parker.southafrica@parker.com

North America

CA – Canada, Milton, Ontario
Tel: +1 905 693 3000

US – USA, Cleveland
Tel: +1 216 896 3000

Asia Pacific

AU – Australia, Castle Hill
Tel: +61 (0)2-9634 7777

CN – China, Shanghai
Tel: +86 21 2899 5000

HK – Hong Kong
Tel: +852 2428 8008

IN – India, Mumbai
Tel: +91 22 6513 7081-85

JP – Japan, Tokyo
Tel: +81 (0)3 6408 3901

KR – South Korea, Seoul
Tel: +82 2 559 0400

MY – Malaysia, Shah Alam
Tel: +60 3 7849 0800

NZ – New Zealand, Mt Wellington
Tel: +64 9 574 1744

SG – Singapore
Tel: +65 6887 6300

TH – Thailand, Bangkok
Tel: +662 717 8140

TW – Taiwan, Taipei
Tel: +886 2 2298 8987

South America

AR – Argentina, Buenos Aires
Tel: +54 3327 44 4129

BR – Brazil, Sao Jose dos Campos
Tel: +55 12 4009 3500

CL – Chile, Santiago
Tel: +56 2 623 1216

MX – Mexico, Apodaca
Tel: +52 81 8156 6000

VE – Venezuela, Caracas
Tel: +58 212 238 5422

Parker Hannifin GmbH

Origa Division Europe
Industriestrasse 8
70794 Filderstadt
Tel. +49 (0)7158 1703-0
Fax +49 (0)7158 64870
Email: info-origa-de@parker.com
www.parker-origa.com
www.parker.com

