

Modular Pneumatic Linear Drive System OSP-P / OSPP-BG



Operating Instructions

ORIGA SYSTEM PLUS

aerospace
climate control
electromechanical
filtration
fluid & gas handling
hydraulics
pneumatics
process control
sealing & shielding



ENGINEERING YOUR SUCCESS.

Chapter	Contents	Page
	Foreword to the Operating Instructions	3
	Safety	4
	Warranty	5
	Transport and Assembly	6
	After sales service	6
	Technical description of the Linear Drive OSP-P	7
	Technical data of basic cylinder	7
	Design and Function.....	7
	Technical Description of Clean Room Cylinder OSP-P	9
	Technical data	9
	Design and function principle of clean room cylinders.....	9
	Technical Description of Basic Guide OSPP-BG	10
	Technical data	10
	Design and Function.....	10
	Installation in machine or plant of OSP-P / OSPP-BG	12
	Preparations	12
	Installation of OSP-P / OSPP-BG.....	12
	Connection diagram.....	13
	Accessories.....	13
	Commissioning	14
	Commissioning of an OSP-P / OSPP-BG linear drive.....	14
	Commissioning of a Complete Plant	14
	Re-commissioning a linear drive after long periods without operation.....	15
	Removal from plant	15
	Service / Maintenance	16
	Maintenance intervals.....	16
	Cleaning.....	16
	Maintenance	17
	Dismantle (not for clean room cylinder)	17
	Dismantle OSP-P Ø 10	17
	Dismantle OSP-P Ø 16 up to Ø 80	18
	Dismantle OSPP-BG (Basic Guide).....	19
	Cylinder OSP-P Reassembly (not Clean Room Cylinder).....	21
	Cylinder OSPP-BG Reassembly	27
	Trouble shooting	31
	List of faults	31
	Cleaning the Inner Sealing Band OSP-P (not Clean Room Cylinder).....	32
	Cleaning the Inner Sealing Band OSPP-BG	33
	Removal / Disposal	33
	Declaration of Incorporation	34
	Spare Parts Lists	35
	OSP-P Ø 10.....	35
	OSP-P Ø16 to Ø80.....	35
	OSPP-BG.....	36
	Replacement Parts (not OSP-P Clean Room Cylinder)	37
	Service Kits (not OSP-P Clean Room Cylinder)	37
	Service Kits OSPP-BG.....	37
	Replacement Parts (not OSP-P Clean Room Cylinder)	38
	Replacement Parts OSPP-BG.....	39
	Lubrication.....	39

This operating manual is the translation of the original German version.
Responsible: Dr.Axel Froeschle, R&D dept.

1 Foreword to the Operating Instructions

The purpose of these Operating Instructions is to assist you in familiarising yourself with the OSP-P and to make use of the functions it has been designed for.

The following instruction describes various types of actuators. They are marked with the following pictograms to show their differences:



OSP-P (Standard)



OSP-P Clean Room Cylinder (Special version)



OSPP-BG (Basic Guide)

The Operating Instructions contain important advice so that you can use the OSP-P safely, reliably and economically. Observance of these Operating Instructions will help you to avoid danger, reduce repair costs and downtime as well as to increase reliability and the service life of the OSP-P.

These Operating Instructions need to be read and applied by all persons working with the OSP-P, including:

- operating the unit, including setup work, trouble shooting during the work sequence, removal of production waste, servicing, handling as well as removing waste of hazardous materials (operating and auxiliary materials);
- maintenance (preventive maintenance, inspection, repairs)

In addition to the Operating Instructions and the mandatory regulations for accident prevention and environmental protection applicable in the user country and at the location of deployment, the standard technical rules and regulations for safe and professional work shall also be observed.

1.1 User's Responsibilities

The following is assumed to be the operator's/organisation's responsibility:

- compliance with EN 89/655 and the national applications
- compliance with the applicable national regulations for safety at work
- authorized use of OSP-P / OSPP-BG
- correct applications of these operating instructions.

Commissioning of the OSP-P / OSPP-BG is forbidden until it has been established that the machine/plant in which it is to be installed complies with the requirements of the EC Machines Directives.

1.2 Explanation of Symbols and Notes

Notes which are highlighted by these symbols help to prevent injury to personnel. Please ensure that all users understand them.

Symbol	Explanation of Symbol	Symbol	Explanation of Symbol
	Danger: This symbol is used if failure to comply carefully with operating instructions, operating sequences, etc. can lead to personal injuries, fatal accidents or damage to the plant.		Attention: Danger of cuts to fingers etc.
	Information: Symbol for tips and notes to facilitate use of machine and to help to prevent damage.		Note: Wear safety glasses
	Attention: Falling load		Note: Wear safety gloves
	Attention: Danger of crushing		Note: Available accessory

Copyright

Copyright 2011 © **Parker Hannifin GmbH** retains the copyright in these operating instructions.

They must not be copied in full or in part, distributed or used in an unauthorized manner for competitive purposes or passed on to others. Contravention may lead to legal action.

Modular Pneumatic Linear Drive System OSP -P / OSPP-BG

1.3 The Type Label

OSP-P Ø10:

The type label is on the barrel

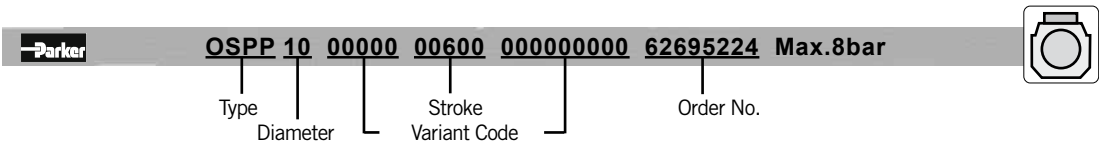

OSP-P Ø16 - Ø80:

The type label is under the red cover strip next to the company name

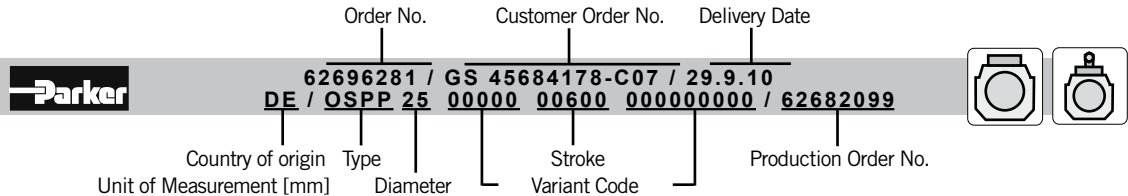

OSPP-BG:

Ø 25 The type label is in the dovetail groove opposite the carriage

Ø 32 The type label is under the red cover strip next to the company name

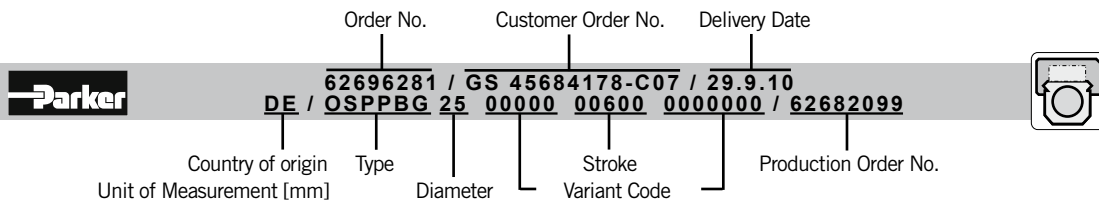

1.4 Produkt Monitoring

Our goal is to supply safe, state-of-the-art products. Therefore we monitor our products constantly after delivery. Please inform us immediately of any recurring malfunctions or problems with the OSP-P / OSPP-BG.

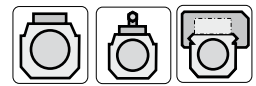

2 Safety

2.1 Authorized Use

The operating safety of the OSP-P / OSPP-BG (called "Linear Drive") is only guaranteed if it is used in authorized applications.

Authorized applications of the Linear Drive are:

- To move loads.
- To exert force.

The Linear Drive is driven by compressed air.

The following should also be observed:

- Conditions laid down in the order confirmation.
- The Operating Instructions.
- Catalogue OSP-P.

If the Linear Drive is used in any other way, this would constitute an „Unauthorized Use“.

This could result in property damage or personal injury for which we cannot be held responsible.

The risk is borne by the user alone.

2.2 Personnel

The operator of the complete plant must ensure that work on the OSP-P is carried out only by authorized and qualified personnel. Authorized personnel are trained engineers of the operator, the manufacturer and the service partner.

2.3 Safety-Conscious Working Practices

The contents of these Operating Instructions, particularly the chapter on "Safety Instructions" must be duly observed under all circumstances.

Before commencing work, all personnel assigned to work with the Linear Drive must have read and thoroughly understood the Operating Instructions - and the chapter on Safety in particular. Doing so while at work is too late !! This also applies in particular to personnel working occasionally on the Linear Drive, e.g., during set-up and maintenance.

The following are not permitted:

- Unauthorized modifications of the Linear Drive.
- Working methods which impair the safety of the Linear Drive.

Observe at the Linear Drive:

- All attached safety instructions.
- Markings for compressed air connections.

Maintain these instructions in a fully legible condition.

Observe also the manufacturer's instructions on lubricants, solvents and cleaning agents.

2.4 Conversions and alterations

The Linear Drives shall not be modified in its construction and safety aspects, without the prior written approval of **Parker Hannifin GmbH**. Any such modifications carried out without approval will rule out all liability on the part of **Parker Hannifin GmbH**.

In principle, no safety and protection devices/equipment shall be dismantled or put out of operation.

When installing special attachments, the assembly regulations of the manufacturer shall be observed as required.

The following regulatory instruments must be observed as a matter of course:

- Relevant rules and regulations for accident prevention.
- Generally recognised safety regulations.
- EU-Directives and
- country-specific provisions.

2.5 Dangers after shutting down the OSP-P / OSPP-BG or the whole plant

Even after venting the whole plant there can still pressure in the cylinder. This may result in uncontrolled movements of the piston.

Reversal of Movement in an Emergency

See the operating instructions for the whole plant.

2.6 Spare parts

The use of original spare parts and accessories authorised by the manufacturer is an important aspect for your safety. The use of other parts may change the characteristics of the OSP-P.

We accept no liability for any consequences resulting from the use of such parts.

3 Warranty

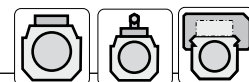

We reserve the right to make alterations to these Operating Instructions as well as to technical details with reference to data and illustrations as contained in these Operating Instructions.

Parker Hannifin GmbH issues no quality and durability guarantees or any guarantees for the suitability for certain purposes unless these are expressly agreed in writing.

Public statements, statements of quality or advertising are not statements of characteristics.

If the user wants to make a claim under the warranty, he needs to notify the fault immediately and describe it precisely in his statement of complaint. Under no circumstances is **Parker Hannifin GmbH** responsible for damage to the product itself or for consequential damage caused by the product, as caused by incorrect and faulty handling of the product. Insofar as **Parker Hannifin GmbH** is responsible for a fault, **Parker Hannifin GmbH** may, at its discretion, either repair/modify the product or replace the item with a new one.

All Linear Drives are provided with an identification plate within the framework of ISO 9000, that is attached to an Linear Drive. This identification plate shall not be removed or destroyed in any way.

A liability of Messrs **Parker Hannifin GmbH** – irrespective of the legal reason – exists only in the event of intentional or gross negligence, culpable injury to life, body, health, in the event of deficiencies with malicious intent of deception or faults the absence of which has been expressly guaranteed.

Furthermore, the company is liable to the extent stipulated by the product liability law regarding personal injury or material damage on objects used privately. In the event of culpable violation of essential contractual obligations, **Parker Hannifin GmbH** is liable also in the case of minor negligence, however, limited to the damage that could be foreseen under the contract.

Any other claims are ruled out.

No warranty shall apply in the event of non-observance of these Operating Instructions, the relevant legal provisions as well as further instructions of the supplier.

In particular, **Parker Hannifin GmbH** is not responsible for stoppages caused by modifications by the customer or other persons. In such cases, we charge the normal repair costs. These are also charged for an inspection of the equipment where no fault can be found on the equipment.

This regulation also applies during the warranty period.

Users have no rights regarding the supply of previous equipment versions or regarding the upgrading of equipment to the current version.

4 Transport and Assembly



Transport

To avoid damages during transportation and storage the linear drives have to be transported as described below and to be protected against dirt, humidity and violence by means of appropriate protective packing.



Danger caused by falling load

Incorrect transport and assembly of the linear drive can:

- Endanger human life.
- Result in material damage.

Transport of linear drives:

Avoid deflection of the linear drive!

- If necessary, carry long and thin linear drives with several persons.

Transport of the packaged linear drive with a crane or a forked-lift truck.
(see illustrations on the right side)

- Apply ropes of appropriate length with a load application ratio as shown or position the fork-lift truck at the appropriate points.
- In the case of very long linear drives always use appropriate harness such as equalizers or fixtures in order to avoid deflection of the linear drives.

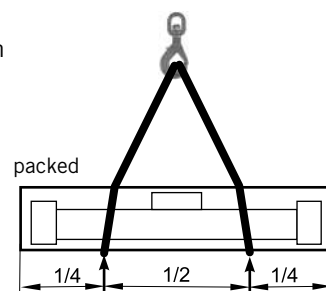

Information

Transport damage and missing parts are to be reported immediately and in writing to the transport company or to Parker Hannifin GmbH or to the delivery company.

Storage

Where storage or interim storage is involved, you must observe the following:

- Dry, dust- and vibration-free storage.
- On a **flat surface**.
- Outdoors under a suitable covering.

You must avoid deflection (bending) of the linear drive !

5 After sales service

Spare parts and after sales service addresses

Refer to the last page of these Operating Instructions.

Spare parts list

For the purposes of preventive maintenance for the linear drives, we offer seal kit sets, service packages and spare parts (refer to chapter 17 on page 35).

Please observe our homepage www.origa-service.com

6 Technical description of the Linear Drive OSP-P

6.1 Technical data of basic cylinder

For further detailed information on

- dimensions
- space requirements, mounting dimensions
- forces and loads
- speeds and cushioning energy
- weights

and additional data see **catalogue OSP-P**.

Operating pressure range:	$p_{\max} = 8 \text{ bar}$.
Speed:	$> 0,005 \text{ m/s}$ ($\varnothing 10 > 0,12 \text{ m/s}$)
Compressed air requirements:	Free of water and dirt. Additional lubrication with oil mist is not necessary.
Noise level:	The sound emission values (sound level) of the linear drives are below 70 dB(A).
Installation:	In any position
Temperature range:	From -10° C to 80° C .

The right to introduce technical modifications is reserved.



Information

With oil mist lubrication, the cylinder must be supplied with oil constantly while in operation.

6.2 Design and Function

6.2.1 Design Features OSP-P, Linear Drive $\varnothing 10$

- The OSP-P is a pneumatic cylinder without piston rod.
- The longitudinal slot in the cylinder is sealed and protected by stainless steel bands.
- The piston consists of piston yoke, support rings, sealing bands, piston seals, bearing strips and magnets on the inside.
On the outside it includes the carrier and the wipers.
- The load is mounted on a carrier.
- The air supply (from the air connection) goes through the cushion spigot into the cylinder barrel.
- The end cushioning is made via integrated rubber buffer. It cannot be adjusted.
- The cylinder has permanent grease lubrication. Oil lubrications require a constant supply of oil.
- For speeds $< 0,2 \text{ m/s}$ we recommend our slow speed grease.

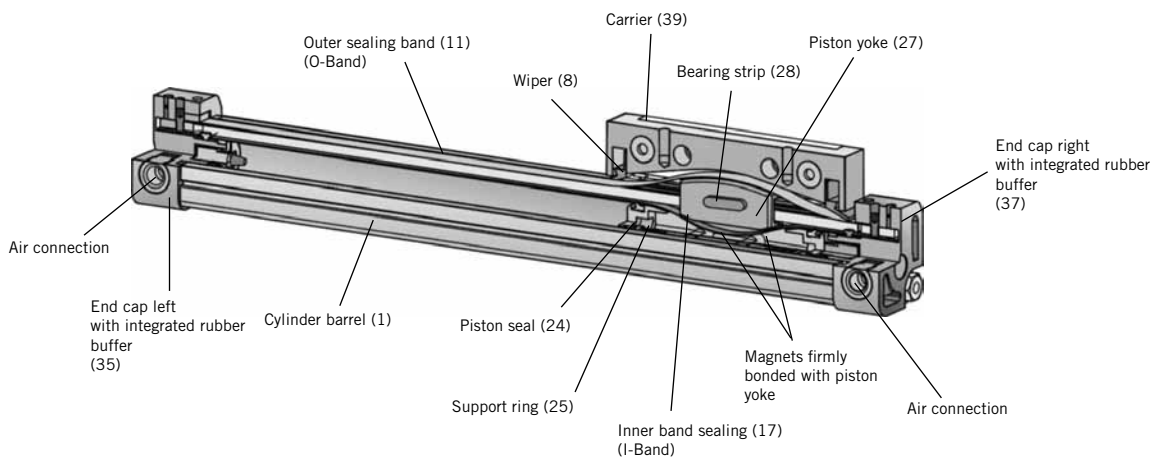

NOTE:

Numbers in brackets refer to parts list item and exploded view drawing of the spare parts list (from chapter 17.1 on page 35).

6.2.3 Design Features OSP-P, Linear Drive Ø16 to Ø80

- The OSP-P is a pneumatic cylinder without piston rod.
- The longitudinal slot in the cylinder is sealed and protected by stainless steel bands.
- The piston consists of piston yoke, support rings, piston seals, cushion seals, slide shoes and magnet set on the inside.
On the outside it includes the carrier and the wipers.
- The load is directly mounted on a piston yoke.
- The air supply (from the air connection) goes through the cushion spigot into the cylinder barrel.
- End cushioning is created by a compression space around the cushion spigot between the cushion seal and the cover, at the end of each cylinder barrel. With the help of a needle valve it can be adjusted at each cylinder end.
- The cylinder has permanent grease lubrication. Oil lubrications require a constant supply of oil.
- For speeds < 0,2 m/s we recommend our slow speed grease.

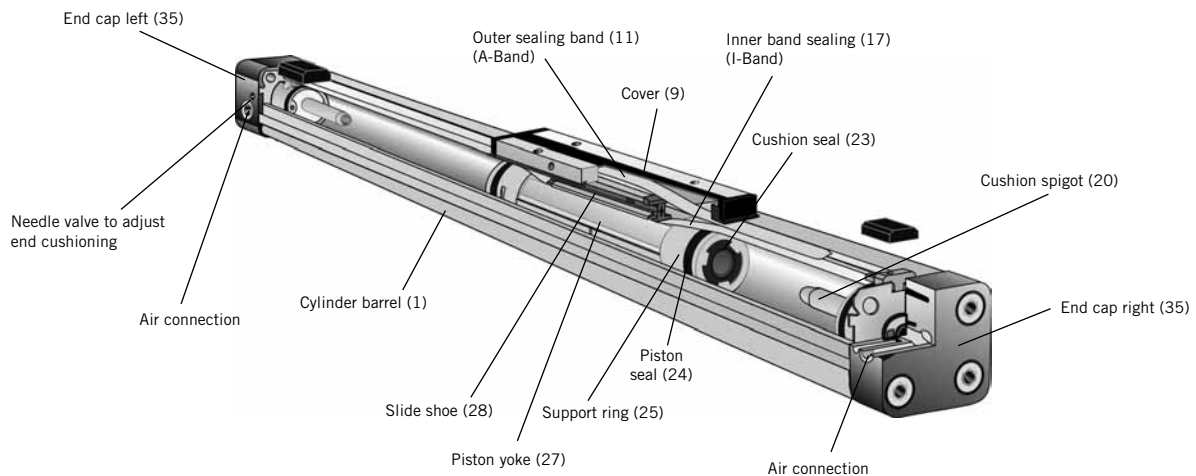

Note:

Numbers in brackets refer to parts list item and exploded view drawing of the spare parts list (from chapter 17.2 on page 35).

6.2.2 Functional Principle and Application Linear Drives Ø10 to Ø80

- The piston is moved by compressed air in the cylinder. In the typical operating mode, both sides of the cylinder are initially charged with compressed air and then the side towards which one wants the cylinder to move is vented. For special applications it is possible to use different types of control if other parameters are also taken into consideration.
- The piston yoke holds the sealing bands in grooves. The force is transmitted directly to the outside.
- The unit is fitted with the help of threads on its front face. Cover mountings can be supplied as accessories.
- For long cylinders, additional mid-section supports should be used (also available as accessories).
For further details please refer to the catalogue.

7 Technical Description of Clean Room Cylinder OSP-P

7.1 Technical data

All other detailed information comply with the OSP-P standard linear drive. For additional details please refer to the **catalogue OSP-P**.

Piston diameter:	16, 25 and 32
Clean room class in accordance with	DIN EN ISO 14644-1 with vacuum suction flow of 4 m ³ /h ISO-Class 4 at $v_{\text{average}} = 0,14$ m/s ISO-Class 5 at $v_{\text{average}} = 0,5$ m/s
Requirements to compressed air:	free of water and dirt. Additional oil mist lubrication not required.
Installation:	in any position
Max. compressed air temperature and ambient temperature:	-10° C to 80° C
Max. stroke:	1200 mm, longer strokes on request



The right to introduce technical modifications is reserved.

IMPORTANT:

Lubrication:

**Permanent grease lubrication
(additional oil mist lubrication not recommended).**

Option: slow speed grease.

7.2 Design and function principle of clean room cylinders

- The piston in the linear drive is moved by compressed air. In the typical operating mode, both sides of the cylinder are initially charged with compressed air and then the side towards which one wants the piston to move is vented. For special applications it is possible to use different types of control if other parameters are also taken into account.
- The unit is fitted with the help of threads on its front face. Cover mountings can be supplied as original accessories.
- The load is directly mounted on the piston.
- The longitudinal slot in the cylinder is sealed and protected by stainless steel bands.
- The difference between the clean room cylinder OSP-P and the rodless standard linear drive OSP-P is that a vacuum is created between the internal and the external steel band. To generate the vacuum there are two air connections where a vacuum pump can be connected. To ensure proper extraction of the particle emission a vacuum suction flow of 4 m³/h is recommended.
- End cushioning is infinitely variable (see cushioning diagram in catalogue OSP-P).
- For speed ranges < 0.2 m/s we recommend our slow speed grease.
- All fixing screws are of stainless material.

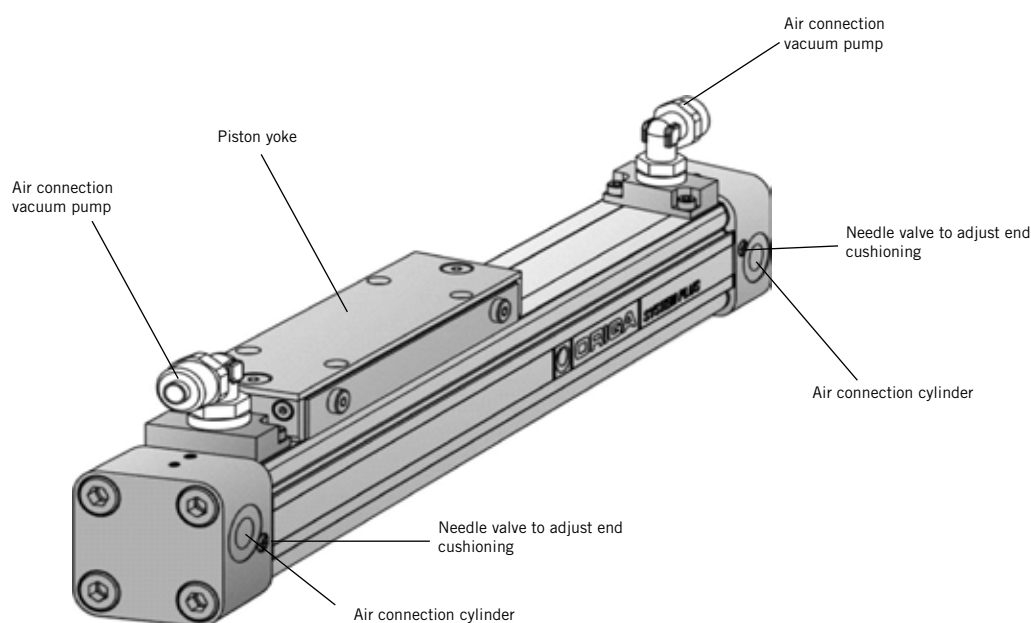

8 Technical Description of Basic Guide OSPP-BG



8.1 Technical data

For further detailed information on

- dimensions
- space requirements, mounting dimensions
- forces and loads
- speeds and cushioning energy
- weights

and additional data see **catalogue OSP-P**.

Operating pressure range:

$p_{\max} = 8 \text{ bar}$.

Compressed air requirements:

Free of water and dirt. Additional lubrication with oil mist is not necessary.

Noise level:

The sound emission values (sound level) of the linear drives are below 70 dB(A).

Installation:

In any position

Temperature range:

From -10° C to 80° C .

The right to introduce technical modifications is reserved.



Information

With oil mist lubrication, the cylinder must be supplied with oil constantly while in operation.

8.2 Design and Function

8.2.1 Design Features OSPP-BG (Basic Guide)

- The OSPP-BG is a pneumatic cylinder without piston rod and with a plainbearing guide, integrated directly into the cylinder barrel.
- The guide carriage consists of plastic slide profiles, support strip, wiper covers with wipers and felts.
- The longitudinal slot in the cylinder is sealed and protected by stainless steel bands.
- The piston consists of piston yoke, support rings, piston seals, cushion seals, bearing strips and magnets on the inside.
On the outside it includes the carrier and the wipers.
- The load is mounted on a carrier.
- The guide can be re-adjusted with screws.
- The air supply (from the air connection) goes through the cushion spigot into the cylinder barrel.
- End cushioning is created by a compression space around the cushion spigot between the cushion seal and the cover, at the end of each cylinder barrel. With the help of a needle valve it can be adjusted at each cylinder end.
- The cylinder has permanent grease lubrication. Oil lubrications require a constant supply of oil.
- The plain bearing guide can be re-lubricated by means of grease nipples located at the guide carriage.
- For speeds $< 0,2 \text{ m/s}$ we recommend our slow speed grease.

OSPP-BG

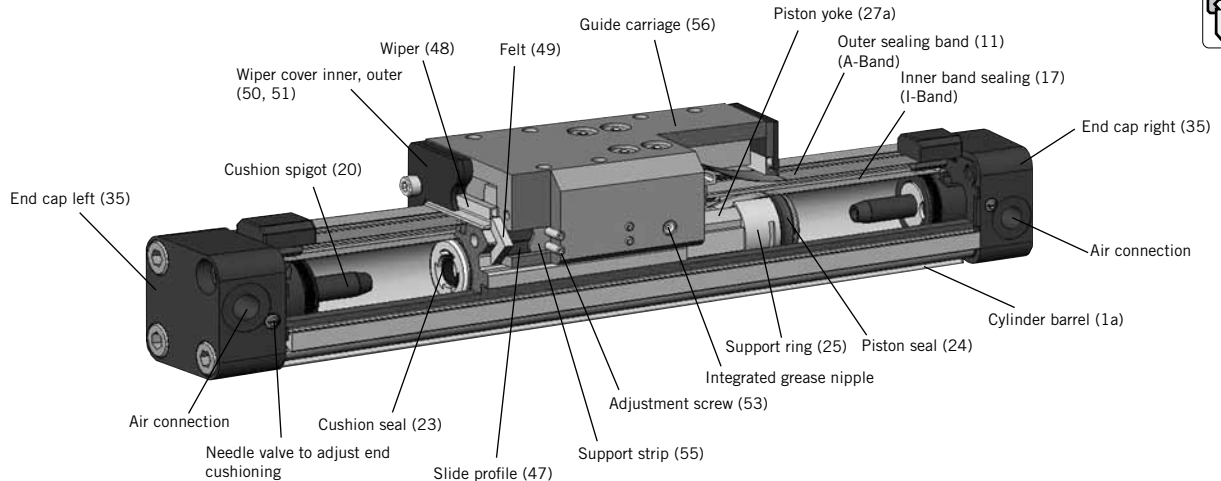
**Note:**

Numbers in brackets refer to parts list item and exploded view drawing of the spare parts list (from chapter 17.3 on page 36).

8.2.2 Design Features OSPP-BG

- The piston in the linear drive is moved by compressed air. In the typical operating mode, both sides of the cylinder are initially charged with compressed air and then the side towards which one wants the piston to move is vented. For special applications it is possible to use different types of control if other parameters are also taken into account.
- The piston yoke holds the sealing bands in grooves. The force is transmitted directly to the outside.
- The unit is fitted with the help of threads on its front face. Cover mountings can be supplied as accessories.
- For long cylinders additional mid-section supports should be used (also available as accessories). For further details please refer to the catalogue.

9 Installation in machine or plant of OSP-P / OSPP-BG

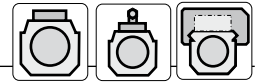

Installation work and commissioning must be carried through by specialists only!

9.1 Preparations

Prior to installation:

- Remove and dispose off all transport devices.

IMPORTANT:

No welding work should be done after the installation of the cylinder.

Welding may damage the sealing system which may cause considerable blow-off noise at the cylinder.



The cylinder can produce uncontrolled movements.

Remove the cylinder first or isolate it electrically.

The assembly itself must be carried out in such a way that

- the applicable rules and regulations are observed as required (e.g. DIN EN 983),
- the linear drive is installed without distortion or warping,
- all connections and operating parts are accessible,
- the type plate and the yellow strip with the „Attention“ note is legible on the cylinder.

Any potential hazards that may exist between this linear drive and customer's items of equipment must be eliminated by the user as required.

9.2 Installation of OSP-P / OSPP-BG

Notes on the application of the linear drives

9.2.1 Mechanical

- In the case of extreme contamination we recommend to install the „piston / guide-carriage-down“ installation and, if necessary, the use of deflectors.
- Fasten the working load to the carrier using only the threaded holes in the carrier.
- Position the working load so that the bending moments on the carrier are below the values shown in the OSP-P catalogue.
- For long cylinders, use mid-section supports from our **OSP-P** catalogue.



OSP-P only:

- Avoid forces exerted by loads carried on **external linear guides**.
Example use a carrier with clevis mounting from our catalogue.

9.2.2 Electrical

- Sensors from our catalogue offer enable your load to be positioned accurately.
- Fit the sensors so that they are not close to ferritic parts or moving loads.
- Use the most favourable mounting slot on the circumference of the cylinder barrel.

9.2.3 Pneumatic

- Actuate the cylinder via two 3/2 way valves ore one 5/3 way valve, normally open.
- Avoid uncontrolled movements during start-up or after an unwanted stop
- Use soft start units, pressurised units or similar items from our catalogue.
- Arrange the control system so that the piston does not travel into a completely exhausted cylinder chamber.
- Adjust the piston speed with throttle non-return valves, these can be screwed directly into the cylinder.
- Use compressed air connections of adequate size.



OSP-P Clean room cylinder

- The length of the hose between vacuum pump and air connection should be as short as possible. Mind a symmetrical arrangement (see connection diagram).



Mind:

Switch on suction device before venting the cylinder chamber.

9.3 Connection diagram

Linear drive OSP-P / OSPP-BG

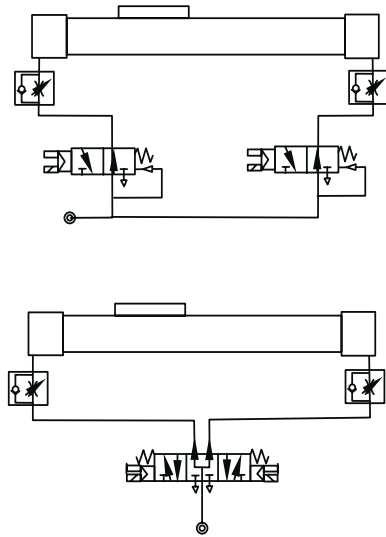

OSP-P clean room cylinder

Vacuum pump
min. vacuum suction flow
4 m³/h

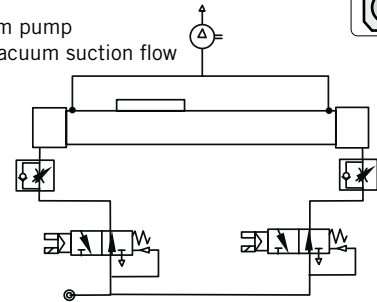

Vacuum pump
min. vacuum suction flow
4 m³/h

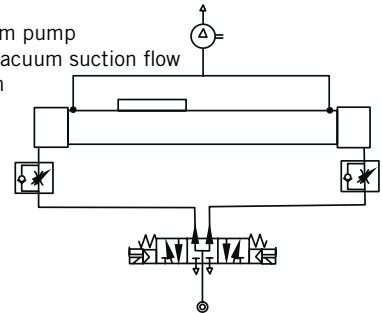

9.4 Accessories

Fastenings and magnetic switch

Owing to the broad range of accessories from our catalogue, the linear drives can be fixed regardless of the surrounding conditions.

Magnetic switches, offered in our catalogue, allow contactless position sensing of the linear drives in their intermediate and end positions.

For further information refer to the OSP-P catalogue.

T-Slot Magnetic Switches P8S

Profilrohr Basic Guide 25

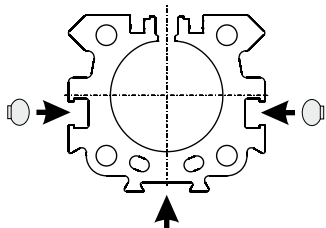

with adapter
in the dove tail
groove *

Profilrohr Basic Guide 32

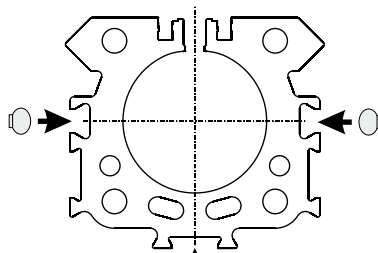

with adapter
in the dove tail
groove *

Profilrohr Basic Guide 40

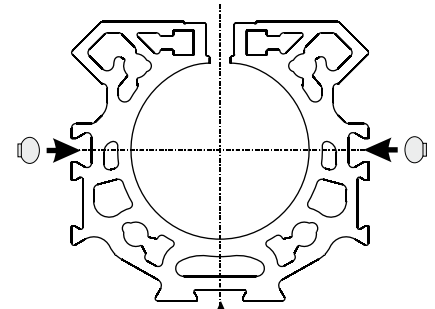

with adapter
in the dove tail
groove *

* Adapter is included in the scope of delivery of the P8S T-slot switches.

Mounting positions in the Basic Guide cylinder profile

- The P8S T-slot magnetic switches can be mounted on three sides of the cylinder barrel.
- On the opposite side of the guide carriage an adapter* for the dovetail groove has to be used.

P8S-T-Slot Switch

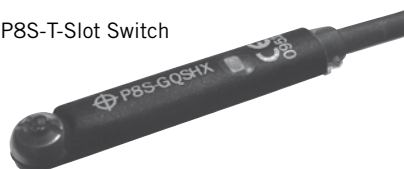

Adapter



10 Commissioning

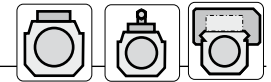

Installation work and commissioning must be carried through by specialists only!

The linear drive can produce quick linear movements with high force. Failure to observe the safety regulations can cause bodily injury as a result of trapping, or damage as a result of collision with other plant parts.



Crushing Hazard



Check before commissioning:

- that the connection arrangements are correct, and
- that there is nothing in the way of the moving load.

During the first start-up, check the function of the proximity and/or the limit switches. First, the linear drive should be allowed to run through the entire moving zone at low speed in order to detect any possible collision areas. These must be removed immediately.

10.1 Commissioning of an OSP-P / OSPP-BG linear drive



- **Make two strokes of the piston / guide carriage by hand without air pressure.**
- Move piston / guide carriage to the middle position.
- Fully screw in both needle valves for end cushioning (not Ø 10).
- Unscrew both needle valves about one half turn (not Ø 10).
- **In the case of clean room cylinders OSP-P switch on suction device before venting the cylinder.**
- Slowly pressurise both cylinder chambers in order to prevent uncontrolled, dangerous movements (soft start valve, accessories in our catalogue),
 the piston stops after a short movement.
- Vent one side,
 the piston travels to end position.
- Start test running.
- Adjust speed with throttle non-return valve.
- Adjust end cushioning with needle valve (not Ø 10).
 The floating end cushion must be adjusted to ensure a shock-free and vibration-free operation.
 Check the permissible weights and speeds in accordance with cushioning diagram in catalogue OSP-P. These values must not be exceeded !

10.2 Commissioning of a Complete Plant



Danger of crushing!

The piston yoke and the guide carriage of linear drives may cause serious injuries during their movements. Protruding edges of other subassemblies or machine components may result in dangerous crushing points.

- Observe instructions for switching on and off the plant, running up of plant, control displays in accordance with the operating instructions.
- Prior to switching on/first start-up of the plant make sure that nobody is within reach of the plant.
- Everybody must be informed that the cylinder (the plant) is about to start.
- Prior to commissioning check all protective devices, limit switches, safety earthings and other protective measures for proper function and completeness. Inspect all parts of the plant for foreign substances.
- Nobody must stay within the danger zone during commissioning.
- Make sure that the correct plant data have been entered for the first start-up.
- Make **two strokes of piston / guide carriage by hand** without air pressure.
- Move piston / guide carriage to mid position.
- Screw in both needle valves for end cushioning fully (not Ø10).
- Unscrew both needle valves about half a turn (not Ø10).
- **For clean room cylinders OSP-P: switch on suction device before venting the cylinder.**
- Pressurise plant slowly in order to avoid uncontrolled, dangerous movements (soft start valve), according in our catalogue.
- Adjust speed with throttle non-return valve.
- Adjust end cushioning with needle valves (not Ø10).
 Check the permissible weights and speeds in accordance with cushioning diagram in catalogue OSP-P.



10.3 Re-commissioning a linear drive after long periods without operation

- Make **two strokes of piston / guide carriage by hand** without air pressure.
- Move piston / guide carriage to mid position.
- Continue as for individual linear drives (chap. 10 on page 14).

11 Removal from plant

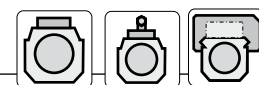

Crushing hazard and danger of eye injuries.

Be extremely careful when removing OSP-P from the plant.
Observe chapter „2 Safety“ on page 4 and the local safety regulation.



Possible hazards are:

- **Residual pressure in lines and adjustment elements**
 - Slowly depressurise linear drive / plant to remove the residual pressure in the lines and adjustment elements.
- **Heavy parts that might fall down after unscrewing**
 - Secure heavy parts that might fall down after unscrewing.
 - Make sure that there are no persons within the reach of any parts that might fall down.
- **Sharp edges**
 - Wear protective gloves to avoid injuries by cutting.
- **Moving the piston / guide carriage**
 - To avoid uncontrolled movements of the piston / guide carriage depressurise the linear drive / plant.
 - In vertical arrangement, move the piston / guide carriage to the bottom final position prior to depressurisation.

Disposal:

Observe the directives and laws on the disposal of ecologically harmful substances.



Attention, Ø16, 25 and 32:

After loosening the screws of the end cap mounting, screws of the end cap (pos.36) must be checked upon their correct torque (see table page 24), before pressure is applied.

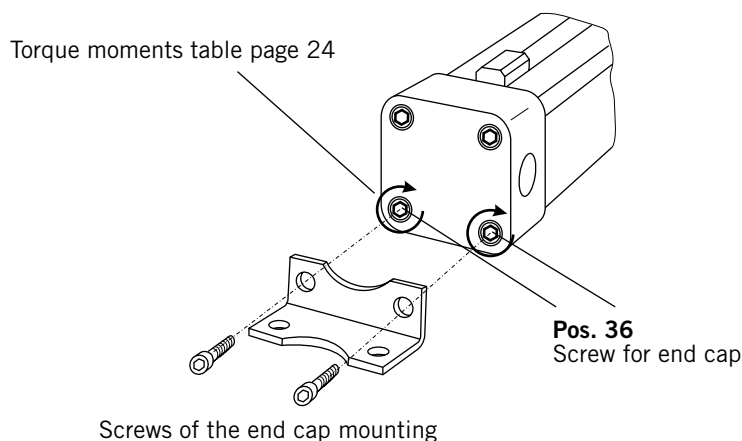

12 Service / Maintenance

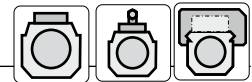

Valid for OSP-P (standard) and OSPP-BG:



Attention!

Maintenance and repair works must be carried out by trained personnel only!
Secure the machine and the working area!



Exception: Clean Room Cylinder !

No maintenance and repair works must be carried out on the clean room cylinder. In the case of failure, the cylinder must be returned to the manufacturer.



Danger of crushing!

Carry out maintenance work only with the machine switched off and the compressed air system depressurized.

Preparation and Things Needed

Have the following things ready:

- Seal kit or service kit.
- Screwdrivers of various sizes.
- Allan keys of various sizes.
- Dismantle the required parts in order to be able to freely move the piston / guide carriage. If necessary, completely remove the linear drive.
- Switch off the main switch and secure it against unintentional switching-on.

12.1 Maintenance intervals

Information only for OSP-P (Standard) and OSPP-BG

	km operated	Maintenance	Instructions
OSP-P 	From 8000	Dismantle linear drive completely if necessary, clean parts and replace worn parts.	see chap. 13
OSPP-BG 	When necessary	Clean inner sealing band.	see chap. 14.2 or 14.3



Observe the operating instructions of the complete plant.

12.2 Cleaning

General



Only use gentle cleansing agents and lint-free cloth to clean the cylinder.

Do not use high-pressure cleaners!

13 Maintenance

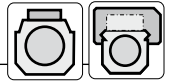

13.1 Dismantle (not for clean room cylinder)



Danger of eye injuries and cuts on fingers etc.



Wear safety glasses where indicated!

There is danger of :

- Eye injuries from flying dirt particles and stressed springs.
- Cuts from sharp edges of inner sealing band.



Wear protective gloves when working with inner sealing band.

Procedure:

- Depressurise cylinder / plant.
- Remove load.

13.2 Dismantle OSP-P Ø 10



Check the position of the parts as shown on the exploded view drawing chap. 17.1 on page 35.

Dismantle the endcap

- Remove two locking screws (13) for outer band, (11) on both ends.
- Remove two locking screws (15) for inner sealing band (17) on both ends.
- Loosen endcap screws (36) and remove.
- Carefully pull off the endcap without wedging. If necessary carefully squeeze screwdriver between cylinder barrel and endcap.
- Remove clamp plate (38) after endcap had been removed.
- Remove locking screw M2x4 (13) for outer cover band (11) and locking screws M2x5 (15) for inner sealing band (17).
- Remove clamping piece for outer band (14) and clamping piece for inner sealing band (16).

Dismantle sealing bands and piston

- Loosen screws (40) from carrier (39) and remove.
- Remove carrier (39) and wiper (8).
- Remove outer band (11).
- Push piston (27) and inner sealing band (17) out of the cylinder barrel.
- Pull out inner sealing band (17) from the piston.
- Remove piston seal (24).

Cleaning and spare part check

- Clean all parts and replace faulty parts.
- Only use original spare parts. We recommend to use the spare parts listed from chap. 17.4 on page 37
- Re-assembly must be carried out on a clean surface.

13.3 Dismantle OSP-P Ø 16 up to Ø 80



Check the position of the parts on the exploded view drawing chap. 17.2 on page 35.

13.3.1 Remove end cap

- Remove screws (36) and end caps (35) and remove end caps (35) on both sides.

13.3.2 Remove sealing bands and piston

- Move piston to middle position.
- Remove all screws (5) for the cover (9).
- Pull off cover (9) with wipers (8), springs (6) and O-rings (7).
- Pull off two clamp covers (12).
- Remove 2 screws (13) and (15) each for the outer and inner band clamping.
- Remove two clamping pieces (14) for outer sealing band.
- Remove outer sealing band (11).
- Remove two clamping pieces (16) for inner sealing band.
- Pull off two cushioning spigots (20) by inserting screwdriver carefully between cushioning spigot (20) and cylinder barrel (1).
- Push piston and inner sealing band (17) out of cylinder bore (1).
- Pull inner sealing band (17) out of piston.

13.3.3 Remove piston

- Pull off both support rings (25) and remove the keepers (29) and (41) together with the magnet (30).
- Remove slide shoes (28) and lateral wipers (31).
- Remove piston seals (24) and cushioning seal (23).

13.3.4 Cleaning and spare part check

- Clean all parts and replace faulty parts.
- Only use original spare parts. We recommend to use the spare parts listed chap. 17.4 on page 37.
- Re-assembly must be carried out on a clean surface.

13.4 Dismantle OSPP-BG (Basic Guide)



Check the position of the parts on the exploded view drawing chap. 17.3 on page 36.

13.4.1 Replacement of the slide profiles only

Dismantle Guide Carriage

- Move guide carriage (56) to middle position.
- Remove the screws (52) from the wiper covers (50, 51).
- Slide the outer wiper cover (51) and the inner wiper cover (50) with the wipers (48) and felts (49) outside off the guide carriage
- Remove the wipers (48) and felts (49). The wiper covers (50,51) remain on the cylinder barrel.
- Remove the screws (46) from the guide carriage (56).
- Slide the guide carriage (56) off the piston yoke (27a).
- Loosen the adjusting screws (53) of the guide.
- Slide the slide profiles (47) and the support strip (55) off the guide carriage (56).
- Clean all the parts.
- Inspect the parts-replace damaged or worn out parts like:
 - slide profiles (47)
 - wipers (48)
 - felts (49)

Refer to the service kits chap. 17.5 on page 37.

Reassembly of the Guide carriage

- Insert the support strip (55) into the guide carriage on the same side as the adjustment screws.
- Insert 2 slide profiles (47) per side in the guide carriage. The edges of the slide profiles in which grooves are cut (to allow grease from the grease nipples to reach the guide rail) must touch each other.
- Align the slide profiles (47) and the wiper cover (55) with the guide carriage (56).

Adjustment of Play

- Tighten the self-locking adjustment screws (53) individually from the middle working outwards, with the specified torque. If non-self-locking screws are used (53), use a locking medium (Loctite low - strength is recommended) and tighten the screws from the middle working outwards until the guide carriage can no longer be moved by hand.
- Tap the sides of the guide carriage (56) gently with a rubber hammer until the slide profiles (47) have settled into position and then tighten all the adjustment screws (53) again (see above).
- Loosen all the adjustment screws (53) about 1/2 to 1 turn individually from the middle working outwards. When correctly adjusted the guide carriage should be easily moveable by hand but without play.
- Position the guide carriage (56) centrally over the piston yoke (27a).
- Fix the guide carriage (56) and the piston yoke (27a) with the screws (46).
- Secure the screws (46) with the Loctite 243.
- The torques to be applied can be found in the table below:

Torque Moments for screws

Pos.	OSPP-BG 25	OSPP-BG 32	OSPP-BG 40
46	9 Nm	14.5 Nm	14.5 Nm
52	5.5 Nm	5.5 Nm	5.5 Nm
53	0.3 - 0.5 Nm	1 - 1.3 Nm	1 - 1.3 Nm

Assembly of the Wiper Covers

- Lubricate the felts (49) with the grease for guidance (IDENT-NO. 10550FIL)
- Insert the wipers (48) and the felts (49) into the inner wiper cover (59). The sealing lip of the wiper must be outwards (see drawing).
- Push the outer wiper cover (51) on the inner wiper cover (50) and slide them both onto the guide carriage (56).
- Tighten them with the screws (52); see table of the torque on page 19.

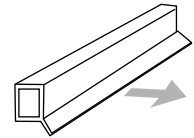

Lubrication

The two grease nipples located on both sides of the guide carriage (56) must be filled with grease for the guiding (IDENT-NO: 10550FIL) until a thin grease film is created by pushing the guide carriage along the cylinder barrel.

13.4.2 Complete disassembly of the OSPP-BG



Check the position of the parts on the exploded view drawing chap. 17.3 on page 36.



Disassembly of the guide carriage according the description in chap. 13.4.1 on page 19.

Remove end cap

- Remove screws (36) and end caps (35) and remove end caps (35) on both sides.

Remove sealing bands and piston

- Move piston to middle position.
- Pull off two clamp covers (12).
- Remove 2 screws (13) and (15) each for the outer and inner band clamping.
- Remove two clamping pieces (14) for outer sealing band.
- Remove outer sealing band (11).
- Remove two clamping pieces (16) for inner sealing band.
- Pull off two cushioning spigots (20) by inserting screwdriver carefully between cushioning spigot (20) and cylinder barrel (1).
- Slide the outer wiper cover (51) and the inner wiper cover (50) off the cylinder barrel (1).
- Slide the guide carriage (56) off the cylinder barrel (1).
- Remove the carrier (54) from the piston yoke (27a).
- Push piston and inner sealing band (17) out of cylinder bore (1).
- Pull inner sealing band (17) out of piston.

Remove piston

- Pull off both support rings (25) and remove the keepers (29) and (41) together with the magnet (30).
- Remove slide shoes (28).
- Remove piston seals (24) and cushioning seal (23).

Cleaning and spare part check

- Clean all parts and replace faulty parts.
Only use original spare parts. We recommend to use the spare parts listed in chap. 17.5 on page 37.
- Re-assembly must be carried out on a clean surface.

13.5 Cylinder OSP-P Reassembly (not Clean Room Cylinder)



Check the position of the parts on the exploded view drawing chap. 17.1 resp. chap. 17.2 on page 35.



Danger of injuries

The sealing bands, especially the inner sealing band are very sharp-edged. Wear gloves!

Preparation:

- Clean and dry sealing bands and cylinder barrel.
- Watch out for damage, especially at the edges of the inner sealing band.

13.5.1 OSP-P Ø10

Prepare piston for installation

Check that piston moves smoothly, as follows:

- Insert piston into cylinder bore (1) and slide it up and down.
- Replace slide shoe and/or support ring (28) if:
 - piston is too tight, or
 - piston has too much play.
- Take piston out again.

Grease cylinder barrel:

- Grease inside of cylinder bore as far as you can reach (Parker Origa-grease) see chap. „17.9 Lubrication“ on page 39.
- Grease the two support rings and piston behind support rings.
- Slide piston up and down a few times (long cylinders, however, should be greased right through).
- Take piston out again.
- Check that cylinder bore has a complete grease film, as follows:
 - point cylinder at a light source and look through it, make sure that there is a grease film on the entire surface – **no dry spot must be left.**
 - Repeat greasing process if required.

Install piston



Information

Piston seals have a delicate sealing lip that must be „pulled“ into the cylinder barrel. For that reason the installation must be carried through as follows:

- Slip on the first piston seal (24) in such a way that the lip and the groove of the piston seal face towards the outside. The centring knob must lock into the recess of the support ring.
- Thoroughly grease the mounted piston seal and fill the groove of the piston seal with grease.



Risk of injury from contact with the sharp edge of the band!

Wear gloves:

- In order to be able to lead the inner sealing band (17) through the piston, bend up the band by approx. 30° on one side outside the band rivet (cut on the bottom side).
- Place inner sealing band (17) together with the piston seal on flat band guide of the support rings, with the „ground-edge“ side on the support ring (see illustration on the right side).
- Push inner sealing band with the bend-up end first about 2-3 cm into the piston.
- Insert the piston end without piston seal into the cylinder barrel as far as 1 cm from the piston seal.
- Insert inner sealing band until the piston seal is placed between band rivet and end of band.
- Insert the piston. **When inserting the second support ring it is imperative to push down the piston shaft in order to avoid damaging the inner sealing band.**
- Push the piston shaft fully into the tube and continue pushing with the sealing band until the support ring emerges on the other side.
- Put the second piston seal on the support ring with the groove on the outside.
- The centring knob must lock into the groove of the support ring.
- Grease the piston seal and fill its groove with grease.
- Slide the inner sealing band into the piston until the piston seal is in the middle between band rivet and end of band.
- Slide inner sealing band until the band rivet is flush with the cylinder barrel at one end.
- Remove excess grease from the ends of the cylinder barrel.

Flat band guide

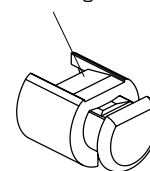

Fitting the End Caps

- Insert clamping pieces for the inner sealing band (16) into the endcap. Observe installation position.  bevel must face towards the air connection.
- Insert clamping pieces for outer band (14) into the cover.
- Fit clamping screw (13) M2x4 for outer band (11) and clamping screws (15) M2x5 for inner sealing band (17).
- Put pressure plate (38) on one end of the inner sealing band (17).
- **Observe position of pressure plate and inner sealing band!**
- Grease cover O-ring (18).
- Mount endcap (35):
insert the inner sealing band (17) with pressure plate (38) below the clamping piece for the inner sealing band; the bevel of the inner sealing band must face towards the air connection.
- Fasten cover screws (36):
observe the required „Torque Moments for screws“ on page 24 as stated.
- Align inner sealing band by slightly moving at the band rivet.
- Tighten clamping screw (15) for inner sealing band, located on the piston side.
- Push piston as far as approx. 50 mm from the opposite end position.
- Put pressure plate (38) onto the opposite end of the inner sealing band (17). Observe position of the pressure plate and of the inner sealing band.
- Grease O-ring of cover (18).
- Mount endcap (37).
- Tighten endcap screws (36): **observe the required tightening torque of screws as stated on page 24.**
- Screw home clamping screw (15) for inner sealing band.

Check tension of inner sealing band

The inner sealing band must be fitted:

- Without pre-tension.
- Without sagging.

Complete cylinder



Attention

See the table „Torque Moments for screws“ on page 24.

- Insert the outer cover band (11) and insert the ends underneath the clamping pieces for the outer band (14). Do not clamp.
- Mark outer cover band (11) on both sides at the end of the cylinder barrel with a pencil.
- Remove outer cover band again and bend down by approx. 20° at the marked spots using a flat pliers.
- Insert outer cover band and insert the ends underneath the clamping pieces (14) for the outer band.
- Push both wipers (8) into the piston groove (17) as far as possible.
- Mount carrier (39) and fix to piston (17) with screws (40). Press carrier (39) down slightly: observe „Torque Moments for screws“ on page 24.
- Fasten clamping screws (13) for outer cover band (11) : „Torque Moments for screws“ on page 24.

13.5.2 OSP-P Ø16 to Ø80

Check the position of the parts on the exploded view drawing chap. 17.3 on page 36.

Inserting the magnet strips (see diagram)

With cylinders from Ø 40 the magnet strips can slip out of the cylinder barrel. Insert these into the cylinder barrel only as follows (the sealing function of your cylinder depends on this).

- Push one magnet strip in, leaving 5 cm sticking out (it must lie on its small side) – or, if it had remained in the cylinder barrel, pull it out a little.
- Place the second magnet strip on its narrow side above the first magnet strip:

If the magnets repel each other:

- Push in the second magnet strip without turning it over (see diagram).

If the magnets attract each other:

- Turn the second magnet strip over i.e. 180° (about its longitudinal axis) and then push it in.

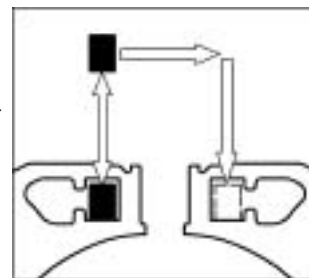

Prepare piston for installation

- Insert both slide shoes (28) into piston yoke. **Colour same as old parts**, because same dimensions.
- Select the two support rings (25) (colour same as old parts),
- Push two keeper plates (29), with magnet (30) between them, into one support ring (except on **OSP-P80**, where magnet system is installed inside piston).
- Push the two support rings on to piston (so that flat band guides are on top - see diagram).
- Clip the two support rings together.

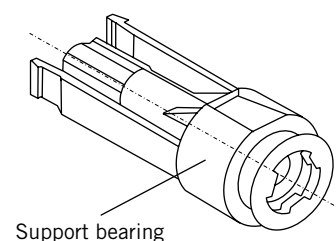

Check that piston moves smoothly, as follows:

- Insert piston into cylinder bore (1) and slide it up and down.
- Replace slide shoe and/or support ring if:
 - piston is too tight, or
 - piston has too much play.
- Take piston out again.
- Insert cushioning seals (23) (so that seal lip shows on outside).

Greasing cylinder bore:

- Grease inside of cylinder bore as far as you can reach, grease inside surface with original grease only (see spare parts chapter „17.9 Lubrication“ on page 39).
- Grease the two support rings and piston behind support rings.
- Slide piston up and down a few times (long cylinders, however, should be greased right through).
- Take piston out again.
- Check that cylinder bore has a complete grease film, as follows:
 - Point cylinder at a light source and look through it, **no dry spot must be left**.
 - Repeat greasing process if required.

Install the piston



Information

Piston seals have a sensitive sealing lip which should only be inserted into the cylinder barrel by pulling action. For that reason the fitting sequence must be carried out as follows:

- Push on one piston seal (24) (so that groove of piston seal shows on outside).
- Push in the two side wipers (31) so that wiper lip shows on outside (see illustration) and adjust their position.
- Grease piston seal and fill its groove with grease.



Risk of injury from contact with the sharp edge of the band!



Wear gloves:

- Place inner sealing band (17) on flat band guide of one support ring (so that „ground edge“ side lies on support ring).
- Push inner sealing band through piston without creasing it.
- Push the piston together with the inner sealing band into the cylinder bore, inserting the side without piston sealing first.
- Place the two side wipers on the cylinder barrel and move piston slowly further along while checking that position of side wipers is symmetrical.
- Put the pin into the centering hole of the inner sealing band, which is located in the cylinder barrel. Push inner sealing band into the cylinder until the other centering hole is flush with the end of the support ring. Do not push centering hole of the inner sealing band over the piston seal.
- Insert piston.

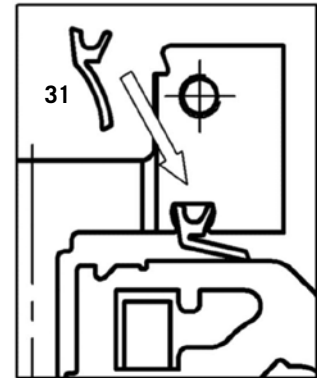

When inserting the second support ring it is imperative to push down the piston in order to avoid damaging the inner sealing band.

- Push the piston completely into the barrel and continue pushing with the sealing band until it emerges on the other side.
- Push the piston together with the inner sealing band into the cylinder bore, inserting the side without piston sealing first.
- Put the pin into the centering hole of the inner sealing band, which is located in the cylinder barrel. Push inner sealing band into the cylinder until the other centering hole is flush with the end of the support ring.
- Move the piston to the middle until one side of the inner sealing band is flush with the cylinder barrel.
- Check again that position of side wipers is symmetrical.
- Remove excess grease from ends of cylinder barrel.

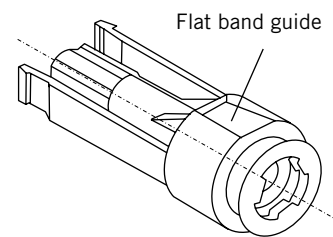

Torque Moments for screws



The tightening torques for screws stated in the table below must be observed during the following assembly sequence. This guarantees the safe function of the cylinder during operation.

Cylinder	Screw (36) for end cap (35 and 37)		Screw (5) for cover (9)		Screw (15) for inner-band (17)		Screw (13) for outer-band (11)		Screw (40) for carrier (39)	
	M	Torque	M	Torque	M	Torque	M	Torque	M	Torque
-P10	M3	0.7 Nm ± 0.1	-	-	M2	0.1 Nm ± 0.01	M2	0.1 Nm ± 0.01	M3	1.2 Nm ± 0.2
-P16	M4	3.25 Nm ± 0.25	M2	0.11 Nm ± 0.01	M2	0.375 Nm ± 0.025	M2	0.375 Nm ± 0.025		
-P25	M5	6.00 Nm ± 1	M3	0.7 Nm ± 0.1	M2,5	0.7 Nm ± 0.1	M2.5	0.7 Nm ± 0.1		
-P32	M6	10 Nm ± 1.5								
-P40	M6	10 Nm ± 1.5	M3	0.7 Nm ± 0.1	M3	1.2 Nm ± 0.2	M3	1.2 Nm ± 0.2		
-P50										
-P63	M8	25 Nm ± 3.8	M4	1.75 Nm ± 0.25	M3	1.2 Nm ± 0.2	M3	1.2 Nm ± 0.2		
-P80	M10	42.5 Nm ± 2.5								

Insert cushion spigot (20) and install endcap

- Grease O-ring grooves (21), insert O-rings and grease them.
- Grease cushioning spigots (20).
- Place inlay nuts (26) in cushioning spigots with ridges upwards.
- Push cushioning pad (22) on to cushioning spigot (20), mind the correct installation position, bore hole at the cushion spigot must not be closed.



Danger of injuries from sharp edges on Inner Sealing Band.

- Hold end of inner sealing band flush with the end of the barrel and slide piston to about 100 mm from other end of cylinder barrel.
- At that end, push centring tool (see diagram) from above through hole in inner sealing band and hold it.

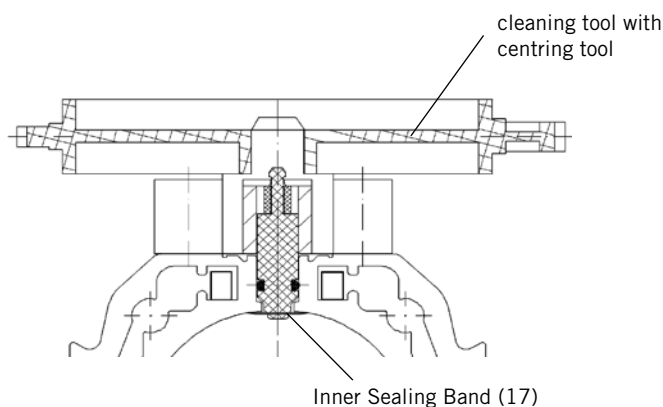

- Insert one cushioning spigot, angled slightly downwards, into cylinder barrel.
- Push cushioning spigot right in with gentle upward pressure and line it up with cylinder barrel,
- Remove centring tool.
- Place the insert nut (26) below the bore hole of the inner sealing band.
- Fit clamping piece (16) and clamping screw (15) but do not screw it down yet.



Information

See the table „Torque Moments for screws“ on page 24.

- Slide piston to about 100 mm from other end of cylinder barrel.
- Pull loose end of inner sealing band as far as possible to end of cylinder barrel.
- Push centring tool from above through hole in inner sealing band and hold it.
- Insert second cushioning spigot, angled slightly downwards, into cylinder barrel.
- Push cushioning spigot right in with gentle upward pressure and line it up with cylinder barrel.
- Remove centring tool.
- Position inlay nut (26) under hole in inner sealing band.
- Fit clamping piece (16) and clamping screw (15) but do not screw it down yet.
- Slide piston to the other end of cylinder barrel.
- Grease face of cushioning spigots and insert O-rings (18, 19).
- Fit end caps with air connection on the desired side.
- Tighten screws (36).
- Position inner sealing band (17) the same distance from both ends of cylinder barrel and tighten clamping screw (15) at this end.
- Slide piston to the other end position.
- Adjust position of clamping piece (16) so that inner sealing band (17) lies correctly along the whole slot, without pretension or hanging loose.
- Tighten clamping screw (15) at this end too.

Checking Tension of inner Sealing Band

Inner sealing band must be fitted:

- Without pretension.
- Without hanging loose.

Complete the Cylinder



Information

See the table „Torque Moments for screws“ on page 24.

- Put the two O-rings (7) on cover (9).
- Put on the two springs (6).
- Clip on wipers (8).
- Lay on outer sealing band (11) and centre it.
- Press cover (9) on to piston yoke and fasten it with screws (5).
- Lay on clamping pieces (14) (so that these lie on clamping pieces (16) of inner sealing band).
- Fasten clamping pieces (14) with screws (13).
- Clip on clamp caps. (12).

13.6 Cylinder OSPP-BG Reassembly



Check the position of the parts on the exploded view drawing chap. 17.3 on page 36

Danger of injuries

The sealing bands, especially the inner sealing band are very sharp-edged. Wear gloves!



Preparation:

- Clean and dry sealing bands and cylinder barrel.
- Watch out for damage, especially at the edges of the inner sealing band.

Inserting the magnet strips (see diagram)

With cylinders from Ø 40 the magnet strips can slip out of the cylinder barrel. Insert these into the cylinder barrel only as follows (the sealing function of your cylinder depends on this).

- Push one magnet strip in, leaving 5 cm sticking out (it must lie on its small side, left side in diagram)
- Place the second magnet strip on its narrow side above the first magnet strip:

If the magnets repel each other:

- Push in the second magnet strip without turning it over (see diagram).

If the magnets attract each other:

- Turn the second magnet strip over i.e. 180° (about its longitudinal axis) and then push it in.

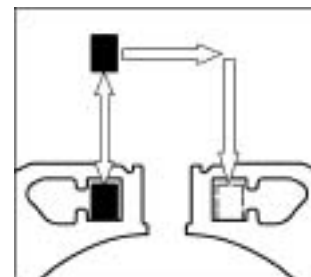

Prepare piston for installation

- Insert both slide shoes (28a) into piston yoke. **Colour same as old parts**, because same dimensions.
- Select the two support rings (25) (colour same as old parts),
- Push two keeper plates (29) and AI-keeper for magnet (41), with magnet (30) between them, into one support ring.
- Push the two support rings on to piston (so that flat band guides are on top - see diagram).
- Clip the two support rings together.

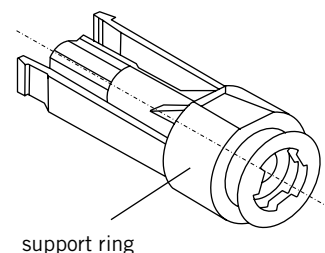

Check that piston moves smoothly, as follows:

- Insert piston into cylinder bore (1) and slide it up and down.
- Replace slide shoe and/or support ring if:
 - piston is too tight, or
 - piston has too much play.
- Take piston out again.
- Insert cushioning seals (23) (so that seal lip shows on outside).

Greasing cylinder bore:

- Grease inside of cylinder bore as far as you can reach, grease inside surface with original grease only (see spare parts chapter „17.9 Lubrication“ on page 39).
- Grease the two support rings and piston behind support rings as a grease deposit.
- Slide piston up and down a few times (long cylinders, however, should be greased right through).
- Take piston out again.
- Check that cylinder bore has a complete grease film, as follows:
 - Point cylinder at a light source and look through it, **no dry spot must be left**.
 - Repeat greasing process if required.

Install the piston



Information

Piston seals have a sensitive sealing lip which should only be inserted into the cylinder barrel by pulling action. For that reason the fitting sequence must be carried out as follows:

- Push on one piston seal (24) (so that groove of piston seal shows on outside).
- Grease piston seal and fill its groove with grease.



Risk of injury from contact with the sharp edge of the band!

Wear gloves:



- Place inner sealing band (17) on flat band guide (see diagram down) of one support ring (so that „ground edge“ side lies on support ring).
- Push inner sealing band through piston without creasing it.
- Push the piston together with the inner sealing band into the cylinder bore, inserting the side without piston sealing first.
- Push the piston into the cylinder barrel until it reaches a position of approx. 1-2 cm in front of the piston seal.
- Put the pin into the centering hole of the inner sealing band, which is located in the cylinder barrel. Push inner sealing band into the cylinder until the other centering hole is flush with the end of the support ring.
- Insert piston.



When inserting the second support ring it is imperative to push down the piston in order to avoid damaging the inner sealing band.

- Push the piston completely into the barrel and continue pushing with the sealing band until the support ring emerges on the other side.
- Place the second piston seal onto the support ring with its groove showing outside.
- Lubricate piston seal and fill its groove with grease.
- Put the pin into the centering hole of the inner sealing band, which is located in the cylinder barrel. Push inner sealing band into the cylinder until the other centering hole is flush with the end of the support ring. Do not push centering hole of the inner sealing band beyond the piston seal.
- Move the piston to the middle until one side of the inner sealing band is flush with the cylinder barrel.
- Remove excess grease from ends of cylinder barrel.

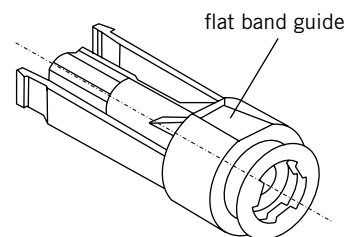

Torque moments for screws



The tightening torques for screws stated in the table below must be observed during the following assembly sequence. This guarantees the safe function of the cylinder during operation.

Linear drive	Screw (36) for cover (35)		Screw (15) for inner-band (17)		Screw (13) for outer band (11)	
	Screw	Torque	Screw	Torque	Screw	Torque
-BG 25	M5	6 Nm ± 1	M2.5	0.7 Nm ± 0.1	M2.5	0.7 Nm ± 0.1
-BG 32	M6	10 Nm ± 1.5				
-BG 40	M6	10 Nm ± 1.5	M3	1.2 Nm ± 0.2	M3	1.2 Nm ± 0.2

Install Guide Carriage

- Push the complete guide carriage (56) carefully onto the cylinder barrel (1). Make sure, that the guide carriage does not scratch on the cylinder barrel.
- Push the inner wiper cover (50) and then the outer wiper cover (51) onto the cylinder barrel.



Insert cushion spigot (20) and install endcap

- Grease O-ring grooves (21), insert O-rings and grease them.
- Grease cushioning spigots (20).
- Place inlay nuts (26) in cushioning spigots with ridges upwards.
- Push cushioning pad (22) on to cushioning spigot (20), mind the correct installation position, bore hole at the cushion spigot must not be closed.



Danger of injuries from sharp edges on Inner Sealing Band!

- Hold end of inner sealing band flush with the end of the barrel and slide piston to about 100 mm from other end of cylinder barrel.
- At that end, push centring tool (see diagram) from above through hole in inner sealing band and hold it.

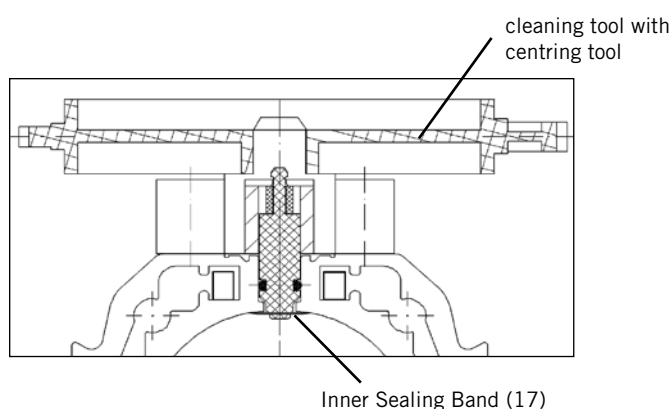

- Insert one cushioning spigot, angled slightly downwards, into cylinder barrel.
- Push cushioning spigot right in with gentle upward pressure and line it up with cylinder barrel.
- Remove centring tool.
- Place the insert nut (26) below the bore hole of the inner sealing band.
- Fit clamping piece (16) and clamping screw (15) but do not screw it down yet.



Information

See the chapter „Torque moments for screws“ on page 28.

- Slide piston to about 100 mm from other end of cylinder barrel.
- Pull loose end of inner sealing band as far as possible to end of cylinder barrel.
- Push centring tool from above through hole in inner sealing band and hold it.
- Insert second cushioning spigot, angled slightly downwards, into cylinder barrel.
- Push cushioning spigot right in with gentle upward pressure and line it up with cylinder barrel.
- Remove centring tool.
- Position inlay nut (26) under hole in inner sealing band.
- Fit clamping piece (16) and clamping screw (15) but do not screw it down yet.
- Slide piston to the other end of cylinder barrel.
- Grease face of cushioning spigots and insert O-rings (18, 19).
- Fit end caps with air connection on the desired side.
- Tighten screws (36).
- Position inner sealing band (17) the same distance from both ends of cylinder barrel and tighten clamping screw (15) at this end.
- Slide piston to the other end position.
- Adjust position of clamping piece (16) so that inner sealing band (17) lies correctly along the whole slot, without pretension or hanging loose.
- Tighten clamping screw (15) at this end too.

Checking Tension of inner Sealing Band

Inner sealing band must be fitted:

- Without pretension.
- Without hanging loose.

Complete the Cylinder OSPP-BG



Information

See the „Torque Moments“ for screws of table on page 19 and page 28.

- Lay on outer sealing band (11) and centre it.
- Insert the two carriers (54) in the piston yoke (27a) and align them with the piston yoke .
- Assembly of the guide carriage (please refer to page 19).
- Adjustment of the play (please refer to page 19).
- Assembly of the wiper covers (please refer to page 20).
- Lubrication (please refer to page 20)
- Lay on clamping pieces (14) (so that these lie on clamping pieces (16) of inner sealing band).
- Fasten clamping pieces (14) with screws (13).
- Clip on clamp caps. (12).



14 Trouble shooting



Faulty OSP-P clean room cylinders must be returned to the manufacturer!



14.1 List of faults

Fault description	Possible cause	Remedy	For instructions please refer to chapters:		
			Standard 	Clean Room 	Basic Guide 
Cylinder leaks somewhere along the inner sealing band.	Inner sealing band (17) dirty.	Clean inner sealing band.	14.2 on page 32	*)	14.3 on page 33
Cylinder leaks at the piston	Piston seal defective (24)	Replace piston seal.	13 on page 17	*)	13.4.2 on page 20
Cylinder leaks at the cover.	O-ring (18, 19, 21) defective.	Replace O-rings.	13 on page 17	*)	13.4.2 on page 20
Piston moves slowly or jerking.	Contamination by air or abrasion.	Completely disassemble, clean and grease cylinder. Replace wearing parts (see wearing parts list).	13 on page 17 and 17 on page 35	*)	13.4.2 on page 20 and 17.3 on page 36
	Poor lubrication.				
	Piston seal (24) defective.				
	Incorrect adjustment of speed (too slow).	Increase speed (cushion needle).	9.2.3 on page 12	9.2.3 on page 12	9.2.3 on page 12
	Operating pressure below 2 bar.	Check operating pressure.	Machine adjustment		
Cylinder lacks slow speed grease at speed $v < 0.2$ m/s.	Use slow speed grease at $v < 0.2$ m/s.	13 on page 17	*)	13.4.2 on page 20	
Piston does not reach the end position.	Cushion needle screwed in at the cover (for cylinders 16 to 80 only).	Adjust cushion needle at the cover. OSP-P for cylinders Ø16 to Ø80 only) and OSPP-BG.	10 on page 14	10 on page 14	10 on page 14
Cylinder impacts too hard at one or both end positions.	Incorrect adjustment of end cushioning: OSP-P nur bei Zyl. 16 bis 80 OSPP-BG all Ø.	Alter adjustment of cushion needle. OSP-P for cylinders Ø16 to Ø80 only) and OSPP-BG.	10 on page 14	10 on page 14	10 on page 14
	Possibly overload.	Install additional buffer, see admissible weights and speeds in accordance with cushioning diagram in OSP-P catalogue.	Please check the technical specifications of the application		
	Cushioning seal (23)*, O-rings at endcap (18, 19) / cushion spigot (20), piston seal (24) or inner sealing band (17) defective. *OSP-P for cylinders Ø16 to Ø80 only. *OSPP-BG all Ø.	Check parts and replace if necessary.	13 on page 17 and page 18	*)	13.4.2 on page 20
The magnetic switch is defective.	There are ferritic parts too close to the magnetic switch.	Use parts on non-magnetic material.	Machine layout		
	Magnetic switch defective.	Replace magnetic switch.	See OSP-P catalogue		
Only for OSPP-BG : Guide carriage runs to slow or with jerks.	Poor lubrication.	Re-lubrication by means of grease nipples.	-	-	„Lubrication“ on page 20
Only for OSPP-BG : Play in the guide carriage.	Abrasion or wear of the slide profiles.	Adjustment of the play or replacement of the slide profiles if necessary.	-	-	„Adjustment of Play“ on page 19

*) No maintenance and repair works must be carried out on the clean room cylinder. In the case of failure, the cylinder must be returned to the manufacturer.

14.2 Cleaning the Inner Sealing Band OSP-P (not Clean Room Cylinder)

Dirt particles can lodge between the inner sealing band and the cylinder bore and cause leakage. Cleaning is then required.



Warning!

Danger of eye injury !

Wear safety glasses where indicated!

- There is danger of eye injury from flying dirt particles.



Danger of cuts on fingers etc.

- Risk of injuries by cutting from contact with the sharp edge of the inner sealing band! Wear protective gloves when handling the inner sealing band.



The piston must be freely movable by hand, all driven parts must be removed. Depending on the local conditions it might become necessary to dismantle the complete cylinder.



Put on safety glasses

Check the position of the parts on the [exploded view drawing on page 35](#).

- Reduce working pressure to 2 bar.
- Move piston to one end position, if necessary move by hand.
- Vent cylinder on the side where the piston is.

OSP-P Ø10:

- Loosen two screws (13) for outer sealing band (11).

OSP-P Ø16 to Ø80:

- Remove two clamp caps (12).
- Remove two screws (13) and clamping piece (14) for outer sealing band (11).
- Pressurise the opposite side to where **the piston not is**, to a maximum pressure of 2 bar (keep other side being vented).
- Lift up one end of outer sealing band (11) without creasing it (see diagram)

NOTE:

If the groove is not completely accessible for the cleaning tool because of short strokes, you must:

- completely remove the cover (9) with wipers (8) and
- the cover band (11).

(See chap. „13.4 Dismantle OSPP-BG (Basic Guide)“ on page 19)

- Insert appropriate blade of cleaning tool (100) into cylinder slot up to the stop, the cylinder sizes are impressed in accordance with the diameter (Ø 10 complies with Ø 16).
- **Carefully** draw cleaning tool along slot several times → the escaping air blows out and dirt particles.
- **Second side:**
Remove pressure and push piston to other end position.
- Pressurise the opposite side to where **the piston not is**, to a maximum pressure of 2 bar (vent other side).
- Repeat cleaning tool operation at other end of slot.
- Remove pressure and reassemble outer sealing band in reverse order.

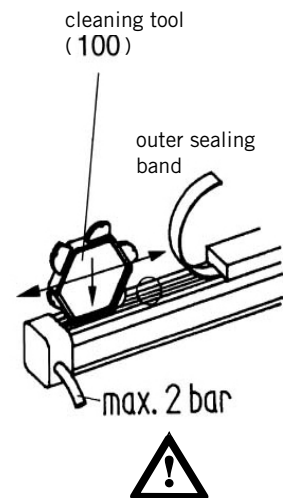

14.3 Cleaning the Inner Sealing Band OSPP-BG



Dirt particles can lodge between the inner sealing band and the cylinder bore and cause leakage. Cleaning is then required.



Warning!

Danger of eye injury !

Wear safety glasses where indicated!

- There is danger of eye injury from flying dirt particles.



Danger of cuts on fingers etc.

- Risk of injuries by cutting from contact with the sharp edge of the inner sealing band!

Wear protective gloves when handling the inner sealing band.



The guide carriage must be freely movable by hand, all driven parts must be removed. Depending on the local conditions it might become necessary to dismantle the complete cylinder.



Put on safety glasses

Check the position of the parts on the [exploded view drawing on page 36](#).

- **Reduce working pressure to 2 bar.**
- Move guide carriage to one end position, if necessary move by hand.
- Vent linear drive on the side where the guide carriage is.
- Remove two clamp caps (12).
- Remove two screws (13) and clamping piece (14) for outer sealing band (11).
- Pressurise the opposite side to where **the piston not is**, to a maximum pressure of 2 bar (keep other side being vented).
- Lift up one end of outer sealing band (11) without creasing it (see diagram).
- Insert appropriate blade of cleaning tool (100) into cylinder slot up to the stop, the cylinder sizes are impressed in accordance with the diameter.
- **Carefully** draw cleaning tool along slot several times \Rightarrow the escaping air blows out and dirt particles.

Second side:

Remove pressure and push piston to other end position.

- Pressurise the opposite side to where **the guide carriage not is**, to a maximum pressure of 2 bar (keep other side being vented).
- Repeat cleaning tool operation at other end of slot.
- Remove pressure and reassemble outer sealing band in reverse order.

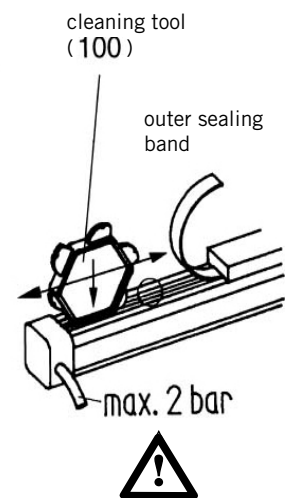

15 Removal / Disposal



Observe all regulations on the disposal of environmentally damaging materials.

16 Declaration of Incorporation



Parker Hannifin Manufacturing Germany GmbH & Co. KG
Pneumatic Division Europe – Origa
Industriestraße 8
70794 Filderstadt (Sielmingen)
Deutschland

Tel +49 (0)7158 1703-0
Fax +49 (0)7158 64870
info-origa-de@parker.com

www.parker-origa.com
www.parker.com

Ust.-Id.-Nr.: DE 277325745
Steuer-Nr. 349/5747/2105

Commerzbank AG
BLZ: 480 400 35
Konto: 7610371
IBAN: DE14 4804 0035 0761 0371 00
SWIFT: COBADEFF480

Declaration of Incorporation

in accordance with EU-Directives Machinery 2006/42/EG

The design of the OSP-P and OSPP-BG (Linear Drives):

Types:	OSP-P 10	OSP-P "Clean Room Cylinder"
	OSP-P 16	and
	OSP-P 25	OSPP-BG25
	OSP-P 32	OSPP-BG32
	OSP-P 40	OSPP-BG40
	OSP-P 50	
	OSP-P 63	
	OSP-P 80	

is developed, designed and manufactured in compliance with EU-Directives Machinery 2006/42/EG and is the sole responsibility of

Company: **Parker Hannifin Manufacturing Germany GmbH & Co. KG**
Pneumatic Division Europe - Origa
Industriestraße 8 · 70794 Filderstadt (Sielmingen)

The following related standards apply:

- DIN EN ISO 12100, Safety of Machinery
- DIN EN 60204.1, Safety of Machinery, Electrical Equipment of Machines
- DIN EN 983, Safety of Machinery - Safety Requirements of Fluid Power Systems and their Components

Full technical documentation is available.

Commissioning of the OSP-P is forbidden until it has been established that the machine/plant in which it is to be installed complies with the requirements of the EU Machines Directives.

The above mentioned pneumatic linear drive systems OSP-P and OSPP-BG are excluded from the area of application of the Pressure Equipment Directive.

Filderstadt, July 2011

ppa. Johann Asperger

ppa. Alexander Keller

17 Spare Parts Lists

17.1 OSP-P Ø 10

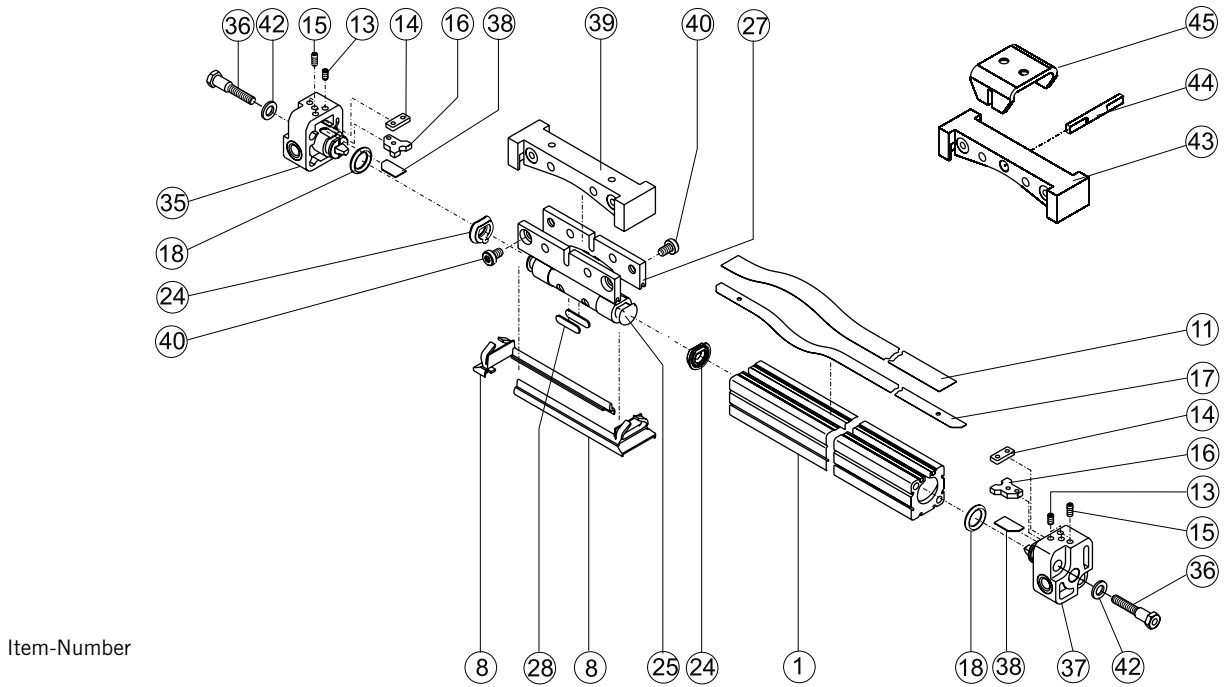

17.2 OSP-P Ø16 to Ø80

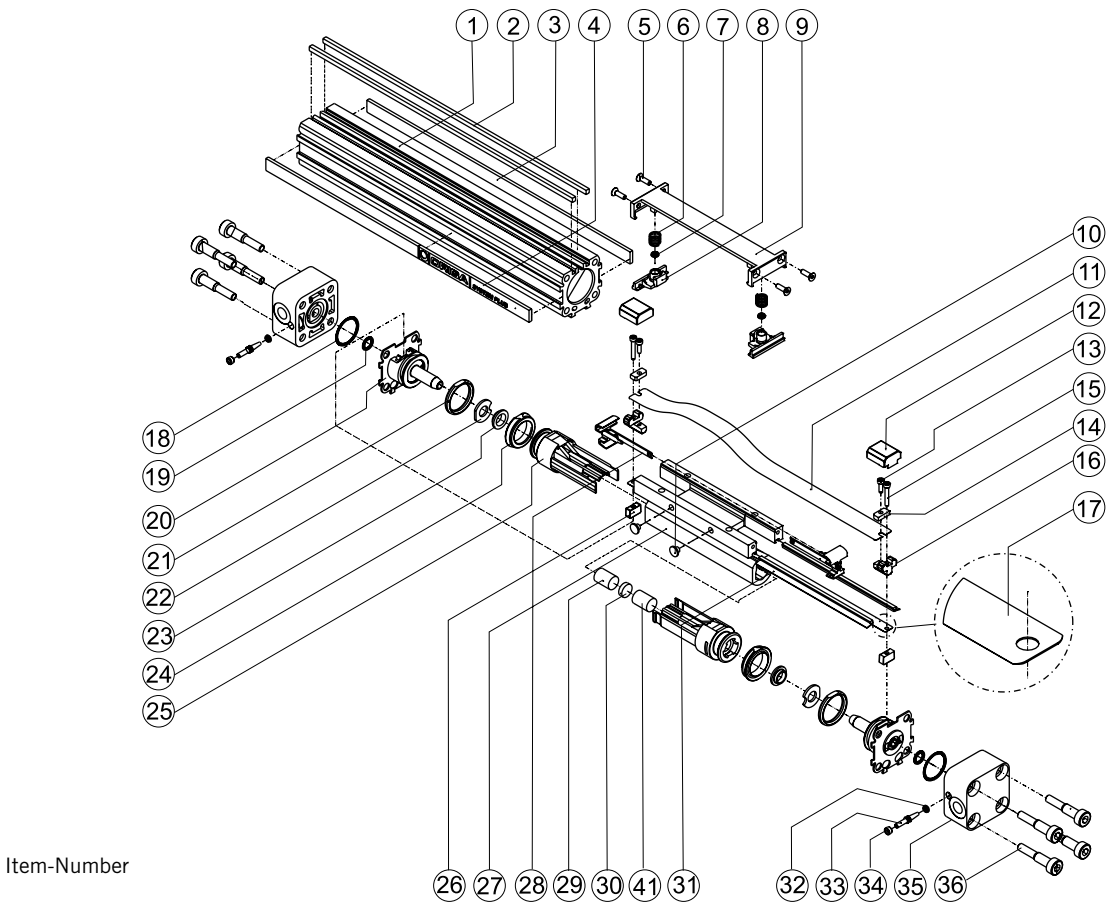

17.3 OSPP-BG

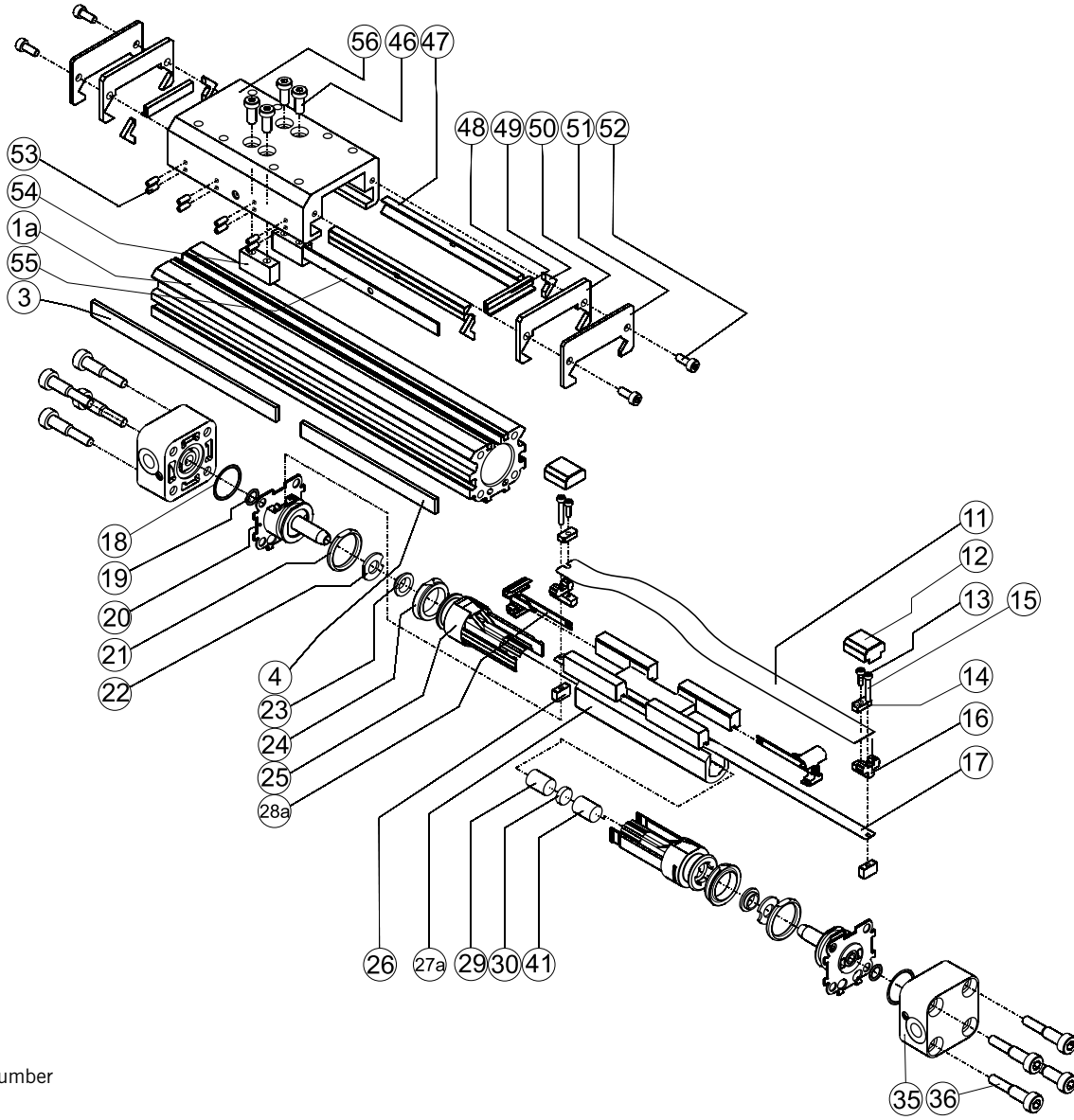

Item-Number

17.4 Replacement Parts (not OSP-P Clean Room Cylinder)



			IDENT-NO. *							
ITEM. Ø10	ITEM. Ø16-80	DESCRIPTION	Ø 10	Ø 16	Ø 25	Ø 32	Ø 40	Ø 50	Ø 63	Ø 80
8,18,24,28	7,8,18,19,21 22,23,24,28,31	SEAL KIT STANDARD (INC. GREASE, CLEANING TOOL AND CENTERING TOOL)	3083	11052	11053	11054	11055	11056	11057	11058
8,18,24,28	7,8,18,19,21, 22,23,24,28,31	SEAL KIT, VITON (INC. GREASE, CLEANING TOOL AND CENTERING TOOL)	3084	11059	11060	11061	11062	11063	11064	11065
-	7,8,18,19,21, 22,23,24,28,31	SEAL KIT STANDARD SLOW SPEED GREASE (INC. GREASE, CLEANING TOOL AND CENTERING TOOL)	-	11071	11072	11073	11074	11075	11076	11077
-	7,8,18,19,21, 22,23,24,28,31	SEAL KIT, VITON SLOW SPEED GREASE (INC. GREASE, CLEANING TOOL AND CENTERING TOOL)	-	11078	11079	11080	11081	11082	11083	11084

* Please use this order pattern: IDENT-NO. + „FIL“, example: 11053FIL

17.5 Service Kits (not OSP-P Clean Room Cylinder)



			IDENT-NO. **							
ITEM. Ø10	ITEM. Ø16-80	DESCRIPTION	Ø 10	Ø 16	Ø 25	Ø 32	Ø 40	Ø 50	Ø 63	Ø 80
8,11,17,18, 24,28	7,8,11,17,18,19, 21,22,23,24 28,31	SERVICE-KIT STANDARD, WITH INNER AND OUTER SEALING- BAND, SEAL KIT	3085	11111	11112	11113	11114	11115	11116	11118
8,11,17,18, 24,28	7,8,11,17,18,19, 21,22,23,24, 28,31	SERVICE-KIT VITON, WITH INNER AND OUTER SEALING- BAND, SEAL KIT	3086	11121	11122	11123	11124	11125	11126	11128
-	7,8,11,17,18, 19,21,22,23,24, 28,31	SERVICE-KIT STANDARD, SLOW SPEED GRASE, WITH INNER AND OUTER SEALING- BAND, SEAL KIT	-	11131	11132	11133	11134	11135	11136	11138
-	7,8,11,17,18, 19,21,22,23,24, 28,31	SERVICE-KIT VITON, SLOW SPEED GRASE, WITH INNER AND OUTER SEALING- BAND, SEAL KIT	-	11141	11142	11143	11144	11145	11146	11148

17.6 Service Kits OSPP-BG



		IDENT-NO. **		
ITEM. Ø25-40	DESCRIPTION	Ø 25	Ø 32	Ø 40
11,17,18,19 21,22,23,24 28a,47,48,49	SERVICE-KIT STANDARD, WITH INNER AND OUTER SEALING BAND	14479	14480	14481
11,17,18,19 21,22,23,24, 28a,47,48,49	SERVICE-KIT VITON, WITH - INNER AND OUTER SEALING- BAND	14482	14483	14484
11,17,18,19 21,22,23,24, 28a,47,48,49	SERVICE-KIT STANDARD, SLOW SPEED GRASE, WITH INNER AND OUTER SEALING BAND	14485	14486	14487
11,17,18,19 21,22,23,24, 28a,47,48,49	SERVICE-KIT VITON, SLOW SPEED GRASE, WITH INNER AND OUTER SEALING BAND	14488	14489	14490

** Service kits must be ordered following the pattern: IDENT-NO. + „stroke length in mm“ (5 digits)
Example: 11112-01000 means Service-Kit Standard for OSPP25 mm, stroke length 1000 mm.

Modular Pneumatic Linear Drive System OSP -P / OSPP-BG

17.7 Replacement Parts (not OSP-P Clean Room Cylinder)

ITEM.	DESCRIPTION	IDENT-NO. * (**)							
		Ø 10	Ø 16	Ø 25	Ø 32	Ø 40	Ø 50	Ø 63	Ø 80
1, 2	CYLINDER BARREL WITH MAGNETSTRIP **	3003	10346	10002	10293	10062	10232	10381	10417
3	COVER RAIL BY THE METER	-	10468	10468	10468	10468	10468	10468	10468
4	COVER RAIL FOR TYPE LABEL	-	10469	10469	10469	10469	10469	10469	10469
5	COUNTER SUNK SCREW FOR COVER	-	10342	10724	10724	10724	10724	10384	10384
5	COUNTER SUNK SCREW FOR COVER, STAINLESS	-	10343	10761	10761	10761	10761	10687	10687
6	SPRING FOR WIPER	-	10354	10084	10084	10110	10084	10084	10084
6	SPRING FOR WIPER, STAINLESS	-	10355	10104	10104	10118	10104	10104	10104
7	O-RING FOR SCRAPER	-	10344	10689	10689	10689	10689	10689	10689
7	O-RING FOR SCRAPER VITON	-	10345	10756	10756	10756	10756	10756	10756
8	SCRAPER	3062	10318	10026	10026	10026	10026	10026	10026
9	WIPER COVER	-	10317	10027	10085	10085	10218	10379	10420
10	COVER PLUG FOR PISTON YOKE	-	-	10674	10674	10674	10674	10674	10674
11	OUTER SEALING BAND CUT TO STROKE **	3008	10348	10004	10295	10064	10234	10367	10419
12	CLAMP CAP	-	10322	10035	10035	10091	10091	10091	10091
13	CLAMPING SCREW FOR OUTER BAND	-	10316	3687	3687	3419	3419	3419	3419
13	CLAMPING SCREW FOR OUTER BAND, STAINLESS	2809	10337	10688	10688	4052	4052	4052	4052
14	CLAMPING PIECE FOR OUTER BAND	3022	10333	10052	10052	10109	10109	10109	10109
14	CLAMPING PIECE FOR OUTER BAND, STAINLESS	-	10333	10058	10058	10109	10109	10109	10109
15	CLAMPING SCREW FOR INNER BAND	0846	10336	11975	11975	13284	13284	13284	13285
16	CLAMPING PIECE FOR INNER BAND	3021	10335	10034	10034	10090	10090	10090	10410
17	INNER SEALING BAND CUT TO STROKE **	3005	10347	10003	10294	10063	10233	10380	10418
18	O-RING FOR END CAP, OUTER	3023	10313	10039	10273	10097	10222	10390	10435
18	O-RING FOR END CAP, OUTER VITON	3029	10349	10754	10758	10752	10760	10391	10436
19	O-RING FOR END CAP, INNER	-	10314	10040	0627	3614	2526	10388	10437
19	O-RING FOR END CAP, INNER VITON	-	10350	10755	10759	10757	2527	10389	10438
20	CUSHIONING SPIGOT	-	10310	10028	10265	10086	10205	10363	10405
21	O-RING FOR CUSHIONING SPIGOT	-	10338	10697	10292	10097	1245	10392	10433
21	O-RING FOR CUSHIONING SPIGOT, VITON	-	10339	10698	1032	10752	1246	10393	10434
22	CUSHIONING DISK	-	10311	10031	10266	10089	10212	10364	10416
23	CUSHIONING SEAL	-	0751	1054	10267	1277	10213	10383	10428
23	CUSHIONING SEAL, VITON	-	0752	1055	10291	1278	10229	4906	10429
24	PISTON SEAL	3035	0745	1052	1072	1275	1325	1345	1375
24	PISTON SEAL, VITON	3096	0746	1053	1073	1276	1326	1346	1376
25	SUPPORT RING WHITE	3033	10303	10008	10268	10067	10211	10368	10421
25	SUPPORT RING RED	-	10325	10009	10276	10068	10219	10369	10422
25	SUPPORT RING GREEN	-	10326	10010	10277	10069	10220	10370	10423
26	INLAY NUT	-	10330	10051	10051	10108	10108	10108	10408
27	PISTON YOKE	-	10302	10007	10262	10066	10202	10366	10431
27	PISTON YOKE, SUPPORT RING WHITE WITH MAGNET	3053	-	-	-	-	-	-	-
28	BEARING STRIP	3036	-	-	-	-	-	-	-
28	SLIDE SHOE, WHITE	-	10340	10020	10269	10081	10214	10371	10424
28	SLIDE SHOE, RED	-	10305	10021	10270	10082	10215	10372	10425
28	SLIDE SHOE, GREEN	-	10312	10022	10271	10079	10216	10373	10426
28	SLIDE SHOE, BLUE	-	10341	10023	10272	10080	10217	10374	10427
29	KEEPER PLATE FOR MAGNET	-	10351	10057	10287	10117	10226	10387	10226
30	MAGNET	-	10331	10056	10286	10116	10225	10386	10225
31	WIPER (SIDE)	-	10329	10025	10083	10083	10224	10394	10442
35	END CAP STANDARD COMPLETE	-	20530	20534	20542	20550	20558	20566	20574
35	END CAP STANDARD COMPLETE, VITON	-	20531	20535	20543	20551	20559	20567	20575
35	END CAP, END AIR PORT, COMPLETE	-	20532	20536	20544	20552	20560	20568	20576
35	END CAP, END AIR PORT, COMPLETE VITON	-	20533	20537	20545	20553	20561	20569	20577
35	END CAP, AIR ONE END LEFT, COMPLETE	-	-	20538	20546	20554	20562	20570	20578
35	END CAP, AIR ONE END RIGHT COMPLETE	-	-	20540	20548	20556	20564	20572	20580
35	END CAP, AIR ONE END LEFT, COMP., VITON	-	-	20539	20547	20555	20563	20571	20579
35	END CAP, AIR ONE END RIGHT, COMP., VITON	-	-	20541	20549	20557	20565	20573	20581
35	END CAP LEFT STANDARD	3015	-	-	-	-	-	-	-
35	END CAP LEFT VITON	3027	-	-	-	-	-	-	-

* Please use this order pattern: IDENT-NO. + „FIL“, example: 10007FIL

** Please use this order pattern: IDENT-Nr. + „stroke in mm“ (5 digits)

Example: Cylinder Barrel with Magnetstrip D.16 mm, stroke 1000 mm: 10346-01000

Replacement Parts (continued)



ITEM.	DESCRIPTION	IDENT-NO. *							
		Ø 10	Ø 16	Ø 25	Ø 32	Ø 40	Ø 50	Ø 63	Ø 80
36	SCREW FOR END CAP	0735	10136	10033	10282	0858	1202	10377	10589
36	SCREW FOR END CAP STAINLESS	0795	10328	10046	10283	0859	1215	10378	10589
-	PLUG FOR VALVE NEEDLE HOLE	-	-	-	-	-	-	3434	3186
-	COVER PLUG FOR MAGNET	-	-	-	-	-	-	-	10441
-	SCREW FOR COVER PLUG MAGNET	-	-	-	-	-	-	-	2692
-	WASHER	-	-	-	-	-	-	-	3792
37	END CAP RIGHT STANDARD	3016	-	-	-	-	-	-	-
37	END CAP RIGHT VITON	3028	-	-	-	-	-	-	-
38	PRESSURE PLATE	3097	-	-	-	-	-	-	-
39	CARRIER	3052	-	-	-	-	-	-	-
40	SCREW STANDARD / STAINLESS	3583	-	-	-	-	-	-	-
41	AL-KEEPER FOR MAGNET	-	-	11922	11923	11924	11925	11926	-
42	WASHER STAINLESS	0797	-	-	-	-	-	-	-
43	CARRIER WITH BUSH	3067	-	-	-	-	-	-	-
44	CARRIER PIN	3055	-	-	-	-	-	-	-
45	FORK	3056	-	-	-	-	-	-	-

17.8 Replacement Parts OSPP-BG



ITEM.	DESCRIPTION	IDENT-NO. * (**)		
		Ø 25	Ø 32	Ø 40
1a	CYLINDER BARREL WITH MAGNETSTRIP **	14066	14159	14470
27a	PISTON YOKE	14064	14157	14469
28a	SLIDE SHOE, WHITE	10020	14177	10081
28a	SLIDE SHOE, RED	10021	14178	10082
28a	SLIDE SHOE, GREEN	10022	14179	10079
28a	SLIDE SHOE, BLUE	10023	14180	10080
46	SCREW FOR CARRIER STANDARD	10678	666	666
46	SCREW FOR CARRIER STAINLESS	10679	667	667
47	SLIDE PROFILE FOR BASIC GUIDE	14059	14148	14476
48	WIPER FOR BASIC GUIDE	14060	14149	1683
49	FELT FOR BASIC GUIDE	3329	1619	1665
50	INNER COVER WIPER	14061	14150	14477
51	OUTER COVER WIPER	14062	14152	14478
52	SCREW FOR WIPER COVER	10167	10167	3716
53	SET SCREW	11917	10682	10682
54	CARRIER FOR BASIC GUIDE	14063	14156	14156
55	SUPPORT STRIP BASIC GUIDE	14058	14147	14475
56	GUIDE CARRIAGE FOR BASIC GUIDE	14057	14146	14473

17.9 Lubrication



	IDENT-NR. *
GREASE SLOW SPEED OPERATION 0.2 m/s, TUBE 25 G	3185
GREASE FOR NORMAL SPEED OPERATION, TUBE 25 G	1598
GREASE FOR GUIDE, TUBE 8 ML	10550
GREASE FOR GUIDE, 0.5 KG	11606

* Please use this order pattern: IDENT-NO. + „FIL“, example: 10033FIL

** Please use this order pattern: IDENT-Nr. + „stroke in mm“ (5 digits)

Example: Cylinder Barrel with Magnetstrip D 25 mm, stroke 1000 mm: 14066-01000

Parker Worldwide

Europe, Middle East, Africa

AE – United Arab Emirates,
Dubai

Tel: +971 4 8127100
parker.me@parker.com

AT – Austria, Wiener Neustadt

Tel: +43 (0)2622 23501-0
parker.austria@parker.com

AT – Eastern Europe, Wiener
Neustadt

Tel: +43 (0)2622 23501 900
parker.easteurope@parker.com

AZ – Azerbaijan, Baku

Tel: +994 50 2233 458
parker.azerbaijan@parker.com

BE/LU – Belgium, Nivelles

Tel: +32 (0)67 280 900
parker.belgium@parker.com

BY – Belarus, Minsk

Tel: +375 17 209 9399
parker.belarus@parker.com

CH – Switzerland, Etoy

Tel: +41 (0)21 821 87 00
parker.switzerland@parker.com

CZ – Czech Republic, Klecany

Tel: +420 284 083 111
parker.czechrepublic@parker.com

DE – Germany, Kaarst

Tel: +49 (0)2131 4016 0
parker.germany@parker.com

DK – Denmark, Ballerup

Tel: +45 43 56 04 00
parker.denmark@parker.com

ES – Spain, Madrid

Tel: +34 902 330 001
parker.spain@parker.com

FI – Finland, Vantaa

Tel: +358 (0)20 753 2500
parker.finland@parker.com

FR – France, Contamine s/Arve

Tel: +33 (0)4 50 25 80 25
parker.france@parker.com

GR – Greece, Athens

Tel: +30 210 933 6450
parker.greece@parker.com

HU – Hungary, Budapest

Tel: +36 1 220 4155
parker.hungary@parker.com

IE – Ireland, Dublin

Tel: +353 (0)1 466 6370
parker.ireland@parker.com

IT – Italy, Corsico (MI)

Tel: +39 02 45 19 21
parker.italy@parker.com

KZ – Kazakhstan, Almaty

Tel: +7 7272 505 800
parker.easteurope@parker.com

NL – The Netherlands, Oldenzaal

Tel: +31 (0)541 585 000
parker.nl@parker.com

NO – Norway, Asker

Tel: +47 66 75 34 00
parker.norway@parker.com

PL – Poland, Warsaw

Tel: +48 (0)22 573 24 00
parker.poland@parker.com

PT – Portugal, Leca da Palmeira

Tel: +351 22 999 7360
parker.portugal@parker.com

RO – Romania, Bucharest

Tel: +40 21 252 1382
parker.romania@parker.com

RU – Russia, Moscow

Tel: +7 495 645-2156
parker.russia@parker.com

SE – Sweden, Spånga

Tel: +46 (0)8 59 79 50 00
parker.sweden@parker.com

SK – Slovakia, Banská Bystrica

Tel: +421 484 162 252
parker.slovakia@parker.com

SL – Slovenia, Novo Mesto

Tel: +386 7 337 6650
parker.slovenia@parker.com

TR – Turkey, Istanbul

Tel: +90 216 4997081
parker.turkey@parker.com

UA – Ukraine, Kiev

Tel: +380 44 494 2731
parker.ukraine@parker.com

UK – United Kingdom, Warwick

Tel: +44 (0)1926 317 878
parker.uk@parker.com

ZA – South Africa, Kempton Park

Tel: +27 (0)11 961 0700
parker.southafrica@parker.com

North America

CA – Canada, Milton, Ontario

Tel: +1 905 693 3000

US – USA, Cleveland

Tel: +1 216 896 3000

Asia Pacific

AU – Australia, Castle Hill

Tel: +61 (0)2-9634 7777

CN – China, Shanghai

Tel: +86 21 2899 5000

HK – Hong Kong

Tel: +852 2428 8008

IN – India, Mumbai

Tel: +91 22 6513 7081-85

JP – Japan, Tokyo

Tel: +81 (0)3 6408 3901

KR – South Korea, Seoul

Tel: +82 2 559 0400

MY – Malaysia, Shah Alam

Tel: +60 3 7849 0800

NZ – New Zealand, Mt Wellington

Tel: +64 9 574 1744

SG – Singapore

Tel: +65 6887 6300

TH – Thailand, Bangkok

Tel: +662 717 8140

TW – Taiwan, Taipei

Tel: +886 2 2298 8987

South America

AR – Argentina, Buenos Aires

Tel: +54 3327 44 4129

BR – Brazil, Sao Jose dos Campos

Tel: +55 12 4009 3500

CL – Chile, Santiago

Tel: +56 2 623 1216

MX – Mexico, Apodaca

Tel: +52 81 8156 6000

VE – Venezuela, Caracas

Tel: +58 212 238 5422

Parker Hannifin Manufacturing Germany GmbH & Co. KG

Pneumatic Division Europe – Origa

Industriestraße 8

70794 Filderstadt, Germany

Tel: +49 (0)7158 1703-0

Fax: +49 (0)7158 64870

E-Mail: info-origa-de@parker.com

www.parker-origa.com

www.parker.com

